

## TE MODEL

### ELECTRIC WINCHES

The electric winches are tools for dragging and lifting, its new compact design facilitates installation.

**Features:**

- End of the electrical career.
- Light.
- High capacity cable.

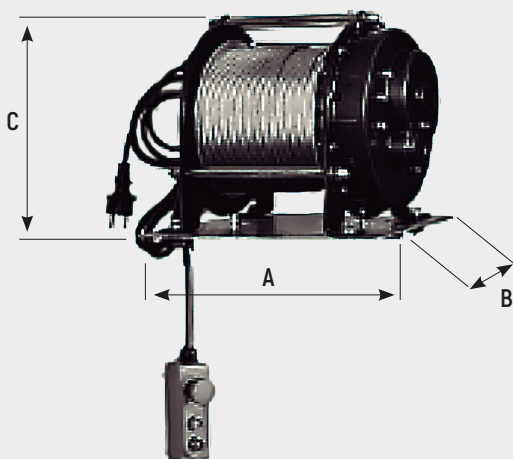

MAIN DIMENSIONS (mm)			NET WEIGHT (Kg)
A	B	C	
232	201	270	31

CODE	ATE400
MODEL	TE 400
LOAD	400 kg.
SPEED	8 m./min.
TENSION	220V/50HZ
POWER	1.300 W
CABLE	5 m./m.
LENGHT	32 mts.

#### RECOMMENDED ACCESSORIES

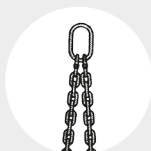

SLING "DO"  
Pag. 84

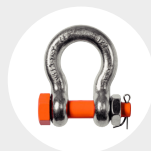

SHACKLES  
Pag. 101