

TA MODEL WALL WINCHES

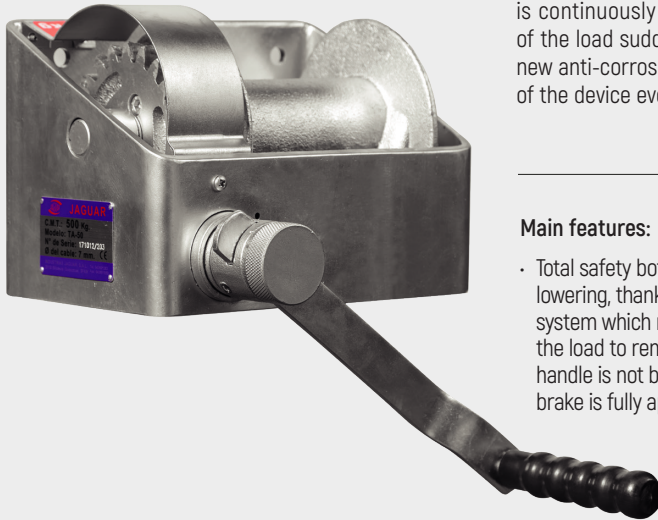

Wall winches are equipped with a crank to be able to go up and down easily. The brake is continuously applied, this way the risk of the load suddenly falling is avoided. The new anti-corrosive finish lengthens the life of the device even outdoors.

Main features:

- Total safety both for lifting and lowering, thanks to the endless screw system which makes it possible for the load to remain Suspended. If the handle is not being operated, the brake is fully applied.
- Allows for the addition of cable according to needs.

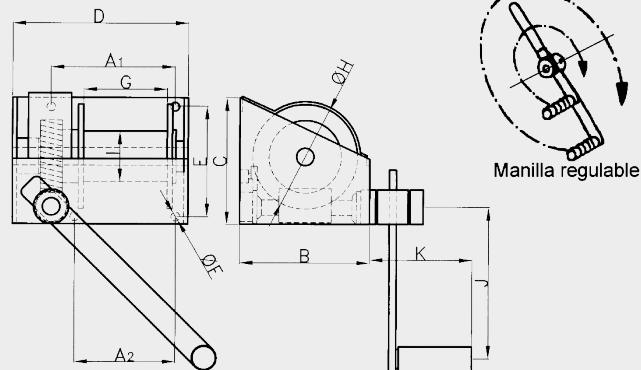

CODE	MODEL	MAX. WORKING LOAD (KG.)	MAIN DIMENSIONS (MM.)											DIAMETER OF CABLE RECOMMENDED (MM.)	CAPACITY OF CABLE IN METRES	FORCE OF THE CRANK (KG.)	WEIGHT APPROX. (KG.)	
			A1	A2	B	C	D	E	F	G	H	I	J					K
AT01000	TA-25	250	137	100	149	152	199	117	11	95	118	58	250	180	6	20	12	10
AT02000	TA-50	500	182	130	181	181	260	140	13	148	150	69	255	180	7	25	13	15,3
AT04000	TA-100	1.000	167	165	280	300	300	248	17	158	244	100	375	210	9	35	14	29,5
AT06000	TA-200	2.000	258	220	340	340	395	295	22	233	285	130	380	194	13	30	22	70

RECOMMENDED ACCESSORIES



**HOOK WITH LATCH
ROTATIONAL**
Pag. 80

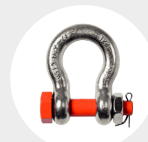

SHACKLES
Pag. 101

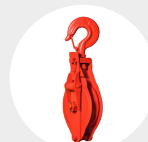

**SNATCH BLOCKS
PBG/PBC MODEL**
Pag. 38