

## GPJM MODEL MEDIUM CRANE SCALES



Very light weigher, compact, easy to transport and store.

**Features:**

- Extra large LED screen.
- Accurate.
- Rechargeable Battery.
- Comes with remote control and battery charger.
- Configuration possibility.
- Precision  $\pm 0,05\%$ .

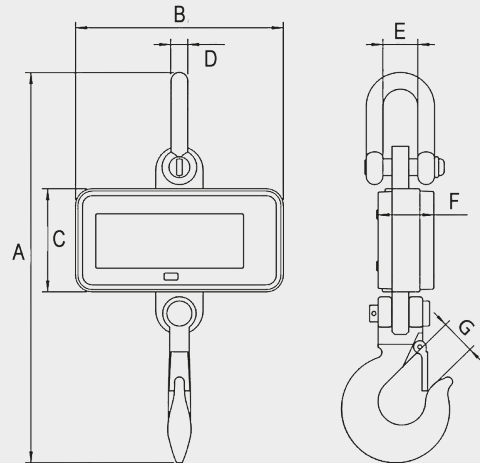

CODE	CAPACITY (Kg.)	DIVISION (Kg.)	MAIN DIMENSIONS (mm)							NET WEIGHT (Kg.)
			A	B	C	D	E	F	G	
GPJM030	300	0,1	280	150	74	12	25	40	25	1,2
GPJM050	500	0,2	280	150	74	12	25	40	25	1,2
GPJM100	1000	0,5	280	150	74	12	25	40	25	1,2

RECOMMENDED ACCESSORIES



MANUAL CHAIN HOISTS  
SERIES 630  
Pag. 20



CHAIN HOIST  
COMPACT MODEL  
Pag. 116



OVAL RING  
Pag. 78