

EQB MODEL SPRING BALANCER WITH LOCK



The spring balancer maintains loads in a suspended state. In this way it can be used to keep tools suspended, allowing the operator greater work freedom and reducing their fatigue.

Recommended for repetitive tasks in industrial, automotive and assembly sectors in general.

Its application makes it possible to significantly reduce the intensity of the workload, improve production efficiency and working conditions.

Main features:

- Additional anchor to prevent falls according to DIN-15112 standard.
- 360° rotating suspension hook.
- Automatic locking allows the load to be positioned and locked at the desired height.
- Compact and lightweight equipped with 3 metres of cable.
- Rubber stopper to avoid impact on load hook return.
- Forged steel load hook with robust safety catch.
- Encapsulated spring for quick and safe replacement.

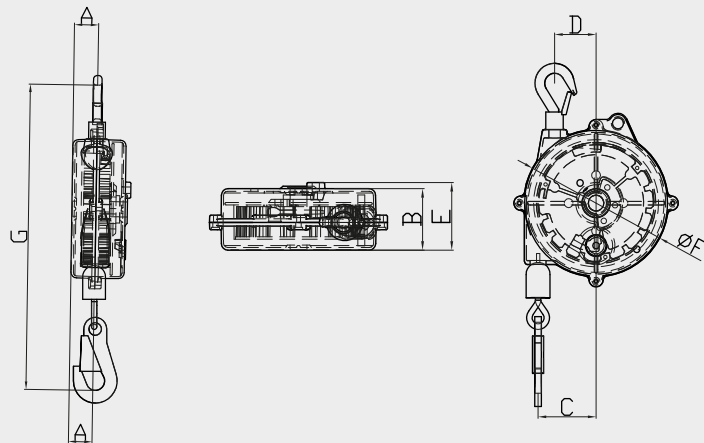

CODE	LOAD CAPACITY (kg)	CABLE LENGTH (m)
EQB13	1-3	3
EQB35	3-5	3

CODE	HEIGHTS (mm)							WEIGHT
	A	B	C	D	E	F Ø	G	
EQB13	25	52	54	42	64	131	291	1.35
EQB35	25	52	54	42	64	131	291	1.60

RECOMMENDED ACCESSORIES



TYPE A TROLLEY
500 SERIES
Pag. 22



ANCHOR CLAMPS
BC MODEL
Pag. 25



SPINDLE CLAW
WF MODEL
Pag. 49