

EQ MODEL SPRING BALANCERS



The spring balancer maintains loads in a suspended state. In this way it can be used to keep tools suspended, allowing the operator greater work freedom and reducing their fatigue.

Recommended for repetitive tasks in industrial, automotive and assembly sectors in general.

Its application makes it possible to significantly reduce the intensity of the workload, improve production efficiency and working conditions.

Main features:

- Additional anchor to prevent falls according to DIN-15112 standard.
- 360° rotating suspension hook.
- Rubber stopper to avoid impact on load hook return.
- Forged steel load hook with robust safety catch.
- Encapsulated spring for quick and safe replacement.

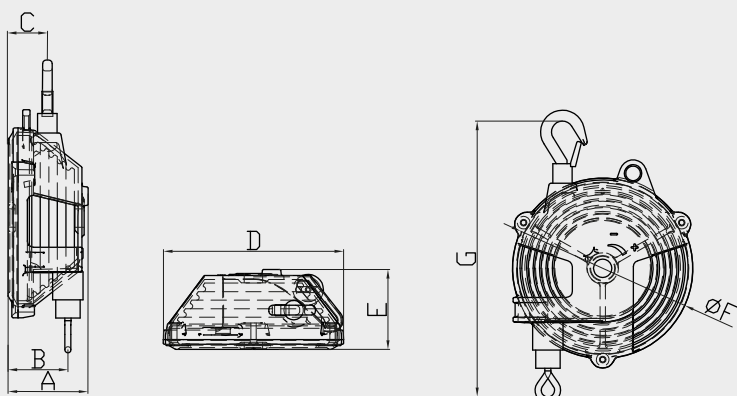

CODE	LOAD CAPACITY (kg)	CABLE LENGTH (m)
EQ13	1-3	1,5
EQ35	3-5	1,5

CODE	HEIGHTS (mm)							WEIGHT (kg)
	A	B	C	D	E	F Ø	G	
EQ13	71	56	35	171	71	149	280	140
EQ35	71	56	35	171	71	149	280	1,55

RECOMMENDED ACCESSORIES



TYPE A TROLLEY
500 SERIES
Pag. 22

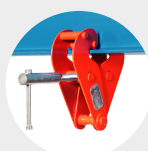

ANCHOR CLAMPS
BC MODEL
Pag. 25



SPINDLE CLAW
WF MODEL
Pag. 49