

EJP4/EJTP4 MODELS

380V THREE PHASE ELECTRIC CHAIN HOIST WITH PUSH TROLLEY



EJP4/EJTP4 Hoist is the new model for frequent use, oriented to the general industry for multiple uses and areas.

- IP55 motor protection.
- Thermal protection of the motor.
- Class dat load chain according to EN 818-7.
- Chain bag included, different sizes.

Features:

- Cast aluminium body.
- Load limiter on all models.

ONE OR TWO SPEEDS



Note:

Check which bag corresponds to chain length.

OPTIONNEL

- INOX AISI316 chain and load hook.
- Remote control.
- Trolley width up to 300mm.

EJ4 - EJTP4 · 250 Kg. - 1.000 Kg.
(schematic only)

EJ4 - EJTP4 · 2.000 Kg.
(schematic only)

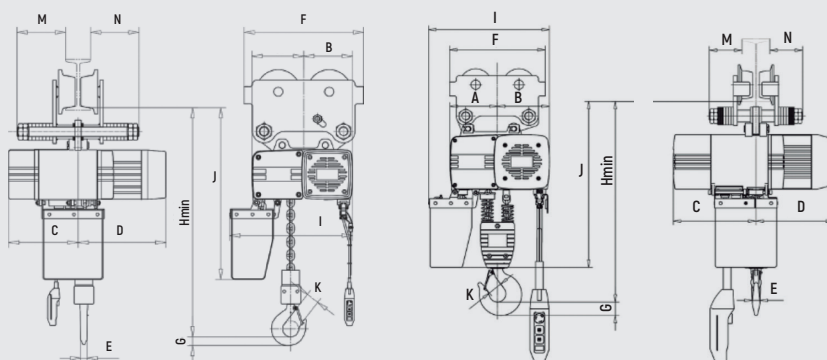

CODE	MODEL	CAPAC. MAX. (kg)	WIDTH OF BEAM (MM)	MINIMUM BEAM RADIUS (MM)	RATING		SPEED OF LIFTING (M/MIN)	POWER OF MOTOR (kW)	No. LINKS	NOISE (dB)	SIZE CHAIN (m/M)
					ISO	FEM					
AEBJ1000	EJP4	250	68-180	1	M5	2M	8	0.4	1	68	Φ4×12
AEBJ1002	EJTP4	250	68-180	1	M5	2m	8/2	0.4/0.1	1	68	Φ4×12
AEBJ2000	EJP4	500	68-180	1	M5	2m	8	0.72	1	65	Φ5×15
AEBJ2002	EJTP4	500	68-180	1	M5	2m	8/2	0.72/0.18	1	65	Φ5×15
AEBJ3000	EJP4	1000	68-180	1	M5	2m	8	1.6	1	73	Φ71×21
AEBJ3002	EJTP4	1000	68-180	1	M5	2m	8/2	1.6/0.4	1	73	Φ71×21
AEBJ4000	EJP4	2000	74-180	1.5	M5	2m	4	1.6	2	73	Φ71×21
AEBJ4002	EJTP4	2000	74-180	1.5	M5	2m	4/1	1.6/0.4	2	73	Φ71×21

CODE	CAPAC. MAX.	H MIN	A	B	C	D	E	F	G	I	J	K	M	N	WEIGHT (kg)
EJP4	250	423	110	123	201	231	18	273	22	290	423	27	115	115	30
EJTP4	250	423	110	123	201	231	18	273	22	290	423	27	115	115	37
EJP4	500	476	118	162	231	209	18	273	22	340	535	27	115	115	39
EJTP4	500	476	118	162	231	209	18	273	22	340	535	27	115	115	42
EJP4	1000	550	128	187	262	250	20	273	25	383	545	31	105	105	51
EJTP4	1000	550	128	187	262	250	20	273	25	383	545	31	105	105	65
EJP4	2000	628	150	165	262	250	27	303	43	383	541	38	104	104	66
EJTP4	2000	628	150	165	262	250	27	303	43	383	541	38	104	104	70

ACCESSOIRES RECOMMANDÉS



ARTICULATED CLAWS
BT MODEL
Pag. 46



"DOL" SLING
Pag. 84



FIXED CLAWS
B MODEL
Pag. 47



WEIGHING HOOK
GPJ MODEL
Pag. 73