

EJ4/EJT4 MODELS

380V THREE-PHASE ELECTRIC HOIST.



ONE OR TWO SPEEDS



The EJ4/EJT4 Hoist is the new model for frequent use, oriented to the general industry for multiple uses and areas.

Features:

- Cast aluminium body.
- Load limiter on all models.

- IP55 motor protection.
- Thermal protection of the motor.
- Class dat load chain according to EN 818-7.
- Chain bag included, different sizes.

Note:

Check which bag corresponds to chain length.

OPTIONAL

- INOX AISI316 chain and load hook.
- Remote control.

EJ4 - EJT4 · 250 Kg. - 1.000 Kg. (schematic only) EJ4 - EJT4 · 2.000 Kg. (schematic only)

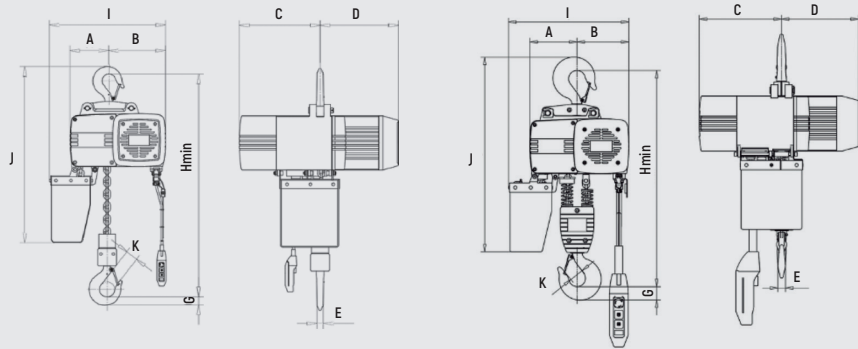

CODE	MODEL	CAPAC. MAX. (kg)	RATING		SPEED OF LIFTING (M/MIN)	POWER OF MOTOR (kW)	No. LINKS	NOISE (dB)	SIZE CHAIN (m/M)
			ISO	FEM					
AEBJ1000	EJP4	250	M5	2M	8	0.4	1	68	Φ4×12
AEBJ1002	EJTP4	250	M5	2m	8/2	0.4/0.1	1	68	Φ4×12
AEBJ2000	EJP4	500	M5	2m	8	0.72	1	65	Φ5×15
AEBJ2002	EJTP4	500	M5	2m	8/2	0.72/0.18	1	65	Φ5×15
AEBJ3000	EJP4	1000	M5	2m	8	1.6	1	73	Φ7.1×21
AEBJ3002	EJTP4	1000	M5	2m	8/2	1.6/0.4	1	73	Φ7.1×21
AEBJ4000	EJP4	2000	M5	2m	4	1.6	2	73	Φ7.1×21
AEBJ4002	EJTP4	2000	M5	2m	4/1	1.6/0.4	2	73	Φ7.1×21

CODE	CAPAC. MAX.	H MIN	A	B	C	D	E	G	I	J	K	WEIGHT (kg)
EJ4	250	415	110	123	201	231	18	22	290	415	27	27
EJT4	250	415	110	123	201	231	18	22	290	415	27	30
EJ4	500	472	118	162	231	209	18	22	340	530	27	29
EJT4	500	472	118	162	231	209	18	22	340	530	27	32
EJ4	1000	565	128	187	262	250	20	25	383	560	31	47
EJT4	1000	565	128	187	262	250	20	25	383	560	31	51
EJ4	2000	675	150	165	262	250	27	43	383	585	38	52
EJT4	2000	675	150	165	262	250	27	43	383	585	38	56

RECOMMENDED ACCESSORIES



ARTICULATED CLAWS
BT MODEL
Pag. 46



"DOL" SLING
Pag. 84



FIXED CLAWS
B MODEL
Pag. 47



WEIGHING HOOK
GPJ MODEL
Pag. 75