

ECJ4 MODEL

SINGLE-PHASE ELECTRIC HOISTS



The ECJ4 hoist is the new SINGLE-PHASE model, thanks to its features it can be used in a multitude of applications where there is no possibility of connecting to a 380-volt three-phase supply.

Features:

- 24V keypad.
- From 500 kg to 2,000 kg
- 220 VOLTS/50 Hz

- Load limiter on all models
- IP54 motor protection
- Class dat load chain according to EN 818-7.
- Thermal protection of the motor
- Forged Steel Safety Lock Hooks
- Chain bag included, different sizes.
- Ergonomic keypad, IP-65 protection

ONE SPEED



Features:

Check which bag corresponds to chain length.

OPTIONAL

- INOX AISI316 chain and load hook.
- Remote control.

ECJ4 · 500 kg - 1,000 kg
(schematic only)

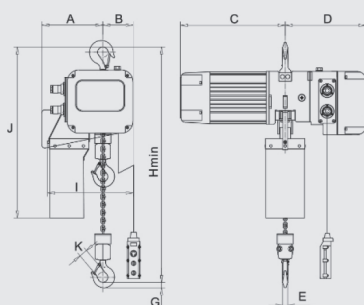

ECJ4 · 2,000 Kg.
(schematic only)

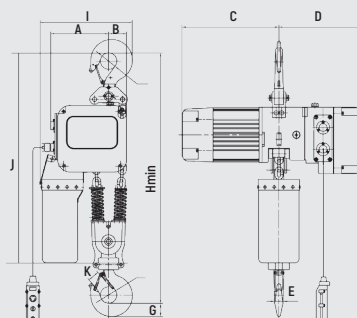

CODE	MOD.	MAXIMUM CAPACITY (kg)	RATING		LIFTING SPEED (m/MIN)	MOTOR POWER (kW)	No. LINKS	Noise (dB)	DIMENS. CHAIN (m/M)
			ISO	FEM					
AECJ2000	ECJ4	500	M5	2m	7.6	1.2	1	78	Φ6.3×19
AECJ3000	ECJ4	1.000	M5	2m	5.0	1.2	1	83	Φ8×24
AECJ4000	ECJ4	2.000	M5	2m	2.5	1.2	2	83	Φ8×24

CODE	MODEL	CAPAC. MAXIMUM	MAIN DIMENSIONS (mm)										WEIGHT (kg)
			H MIN	A	B	C	D	E	G	I	J	K	
AECJ2000	ECJ4	500	410	142	102	390	353	19	22	276	610	27	62
AECJ3000	ECJ4	1.000	460	142	102	390	353	20	25	276	360	31	66
AECJ4000	ECJ4	2.000	650	185	50	390	353	27	43	279	720	38	82

ACCESSOIRES RECOMMANDÉS



MULTIPOSITION CLAMPSBT
MODEL
Pag. 46



SLING "DOL"
Pag. 84



TYPE B TROLLEY
SERIES 500
Pag. 47



CRANE SCALES
GPJ MODEL
Pag. 73