

ECG4 - ECTG4 - ECP4 - ECTP4 MODELS

ELECTRIC CHAIN HOISTS WITH GEARED OR PUSH TROLLEY

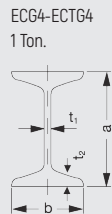

ONE OR TWO SPEEDS



Features:

- IP-54 protection of the motor, IP-65
- protection of the keypad.

OPTIONAL

- Remote control for all models
- Stainless steel chains.
- Stainless steel rotary hook for models of 250 kg, 500 kg and 1000kg.

ECG4 - ECTG4 · 250 Kg- 5.000 Kg (schematic only)

Electric chain hoists with chain trolley with one or two speeds,

ECP4 - ECTP4 · 250 Kg- 5.000 Kg (schematic only)

Electric chain hoists with push trolley with one or two speeds

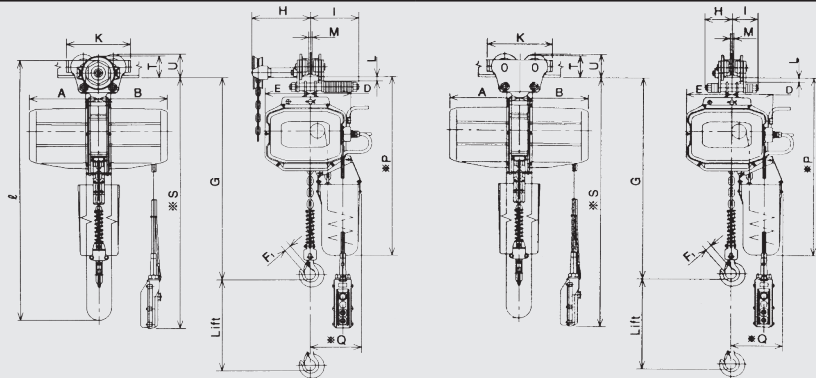

SPECIFICATIONS ONE LIFTING SPEED ECG4 - ECP4

CODE ECG4	CODE ECP4	CAPACITY (Kg)	LIFTING (m)	SPEED LIFTING (m/MINUTE)		POWER OF MOTOR ELEV. (KW)		SERVICE (MIN.)	CHAIN	
				50 HZ	60 HZ	50 HZ	60 HZ		DIA. (mm)	No. OF LEGS
AEAA100	AEBA100	250	3	8,7	10,3	0,4	0,5	30	6,3	1
AEAA200	AEBA200	500	3	8,6	10,1	0,9	1,1		6,3	1
AEAA300	AEBA300	1.000	3	5,6	6,7	1,1	1,3		7,1	1
AEAA400	AEBA400	2.000	3	2,8	3,3	1,1	1,3		7,1	2
AEAA500	AEBA500	3.000	3	4,4	5,2	2,5	3,0		11,2	1
AEAA600	AEBA600	5.000	3	2,6	3,1	2,5	3,0		11,2	2

SPECIFICATIONS TWO LIFTING SPEEDS ECTG4 - ECTP4

CODE ECTG4	CODE ECTP4	CAPACITY (Kg)	LIFTING (m)	SPEED LIFTING (m/MINUTE)				POWER OF MOTOR ELEV. (KW)				SERVICE (MIN.)		CHAIN	
				FAST 50 HZ	SLOW 60 HZ	FAST 50 HZ	SLOW 60 HZ	FAST 50 HZ	SLOW 60 HZ	FAST 50 HZ	SLOW 60 HZ	DIA. (mm)	No. OF LEGS		
AEAA102	AEBA102	250	3	8,7	10,3	2,2	2,6	0,4	0,5	0,10	0,13	30	10	6,3	1
AEAA202	AEBA202	500		8,6	10,1	2,2	2,6	0,9	1,1	0,23	0,28			6,3	1
AEAA302	AEBA302	1.000		5,6	6,7	1,4	1,7	1,1	1,3	0,27	0,33			7,1	1
AEAA402	AEBA402	2.000		2,8	3,3	0,7	0,8	1,1	1,3	0,27	0,33			7,1	2

STANDARD SPECIFICATIONS: MOD. ECG4 - ECTG4, ELECTRIC CHAIN HOISTS WITH TROLLEY CHAIN ECP4 - ECTP4, ELECTRIC HOISTS WITH PUSH TROLLEY, ONE OR TWO SPEEDS, THREE-PHASE, MONOTENSION.

CAPACITY (Kg)	LIFTING (m)	ECG4 - ECTG4 / ECP4 - ECTP4														ECG4 - ECTG4				
		WIDTH OF BEAM B(mm)	MINIMUM RADIUS (m)	HEIGHT MAX. G (mm)	DIMENSIONS PRINCIPALES (mm)											H (mm.)	LEN. CHAIN (m)	WEIGHT NET APPROX. *(Kg)	H (mm.)	WEIGHT NET APPROX. *(Kg)
					A	B	D	E	F1	I	K	L	M	*P	*Q					
250	3	50-140	0,8	585	245	245	137	149	20	105	206	24-12	b-42	770	195	b/2 +275	3	47	b/2 +105	42
500	3	50-140	1,0	620	245	245	137	149	20	105	206	24-12	b-42	770	195	b/2 +275	3	49	b/2 +105	44
1.000	3	58-140	1,5	680	255	255	150	180	25	115	235	24-12	b-42	800	200	b/2 +280	3	65	b/2 +115	59
2.000	3	74-165	2,0	790	255	255	191	127	30	128	270	28-12	b-63	850	240	b/2 +285	3	79	b/2 +128	74
3.000	4	74-203	2,5	910	335	335	195	127	36	133	320	27-12	b-63	1.000	235	b/2 +150	4	131	b/2 +133	127
5.000	4	95-185	2,5	1.120	335	335	247	93	43	166	385	35-12	b-76	1.150	290	b/2 +339	4	185	b/2 +166	175

RECOMMENDED ACCESSORIES



MULTIPOSITION CLAMPS
BT MODEL
Pag. 46



SLING "DOL"
Pag. 84



SIMPLE POSITION CLAMPS
B MODEL
Pag. 47



CRANE SCALES
GPJ MODEL
Pag. 73