

ECE4 - ECTE4 MODELS

ELECTRIC CHAIN HOISTS WITH ELECTRIC TROLLEY



Features:

- IP-54 protection of the motor, IP-65 protection of the keypad.

OPTIONAL

- Remote control for all models
- Stainless steel chains.
- Stainless steel rotary hook for models of 250 kg, 500 kg and 1000kg.

ONE OR TWO SPEEDS

ECE4 - ECTE4 · 250 Kg - 500 Kg. - 1000 Kg - 3000 Kg.
(schematic only)

Electric chain hoists with electric trolley with one or two speeds.

ECP4 - ECTP4 · 2.000 Kg - 5.000 Kg
(schematic only)

Electric chain hoists with electric trolley with one or two speeds.

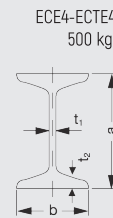
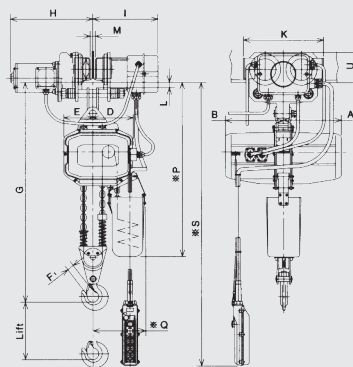
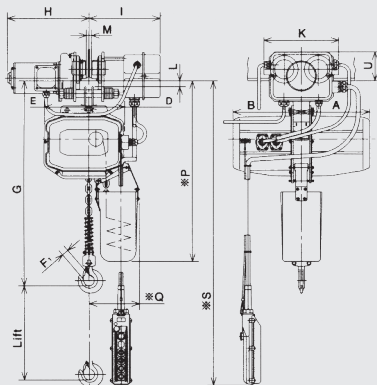

ECE4-ECTE4
500 kg.



SPECIFICATIONS ONE LIFTING SPEED									
CODE ECE4	CAPACITY (Kg)	LIFTING (m.)	SPEED LIFTING (m/MINUTE)		POWER OF MOTOR ELEV. (KW)		SERVICE (MIN.)	CHAIN	
			50 HZ	60 HZ	50 HZ	60 HZ		DIA. (mm.)	No. OF LEGS
AEAA100	250	3	8,7	10,3	0,4	0,5	30	6,3	1
AEAA200	500	3	8,6	10,1	0,9	1,1		6,3	1
AEAA300	1.000	3	5,6	6,7	1,1	1,3		7,1	1
AEAA400	2.000	3	2,8	3,3	1,1	1,3		7,1	2
AEAA500	3.000	3	4,4	5,2	2,5	3,0		11,2	1
AEAA600	5.000	3	2,6	3,1	2,5	3,0		11,2	2

SPECIFICATIONS TWO LIFTING SPEEDS														
CODE ECTP4	CAPACITY (kg)	LEVERAGE (m)	SPEED LIFTING (m/MINUTE)				POWER OF MOTOR ELEV. (KW)				SERVICE (MIN.)		CHAIN	
			FAST		SLOW		FAST		SLOW		FAST	SLOW	DIA. (mm.)	No. OF LEGS
			50 HZ	60 HZ	50 HZ	60 HZ	50 HZ	60 HZ	50 HZ	60 HZ				
AEAA102	250	3	8,7	10,3	2,2	2,6	0,4	0,5	0,10	0,13	30	10	6,3	1
AEAA202	500		8,6	10,1	2,2	2,6	0,9	1,1	0,23	0,28			6,3	1
AEAA302	1.000		5,6	6,7	1,4	1,7	1,1	1,3	0,27	0,33			7,1	1
AEAA402	2.000		2,8	3,3	0,7	0,8	1,1	1,3	0,27	0,33			7,1	2

STANDARD SPECIFICATIONS: MOD. ECP4 - ECTP4, HOISTS WITH ELECTRIC PUSH TROLLEY, ONE OR TWO SPEEDS, THREE-PHASE, MONOTENSION.

CAPACITY (Kg)	VEL. DEL CARRO (M/MINUTO)		POTENCIA MOTOR CARRO (KW.)	SERVICE (MIN.)	WIDTH OF BEAM B(mm)	MÍNIMO RADIO DE CURVA (M.)	HEIGHT MAX. G (mm)	WEIGHT NET APPROX. (Kg)	MAIN DIMENSIONS (mm)											
	50 HZ	60 HZ							A	B	D	E	F1	H	I	K	L	M	*P	*Q
250			0.2	30	58-125	1.0	495	62	245	245	137	149	20	b/2 +280	b/2 +240	240	32-t	b-49	670	195
500			0.2		58-125	1.0	530	65	245	245	137	149	20	b/2 +280	b/2 +240	240	32-t	b-49	670	195
1.000	20	24	0.2		58-125	1.0	565	80	255	255	150	168	25	b/2 +208	b/2 +240	240	32-t	b-49	705	200
2.000			0.4		75-155	1.0	820	110	255	255	191	140	30	b/2 +325	b/2 +250	360	33-t	b-70	790	220
3.000			0.4		95-185	1.5	805	176	350	335	195	150	36	b/2 +330	b/2 +240	390	37-t	b-76	920	235
5.000	10	12	0.4		95-185	1.5	975	229	350	300	247	93	43	b/2 +330	b/2 +245	434	38-t	b-80	1.010	290

OPTIONAL: Trolley speed 10 metres/minute for capacities from 250 to 3000.

RECOMMENDED ACCESSORIES



MULTIPOSITION CLAMPS
BT MODEL
Pag. 46



SLING "DOL"
Pag. 84



SIMPLE POSITION CLAMPS
B MODEL
Pag. 47



CRANE SCALES
GPJ MODEL
Pag. 73