

EC4 MODEL

ONE SPEED ELECTRIC CHAIN HOISTS



ONE SPEED



EC4 500 Kg.

Features:

- IP-54 protection of the motor, IP-65 protection of the keypad.

Note:

- Make sure that the power, voltage and frequency are adequate.
- Design, materials and specifications are subject to change without prior Notification for reasons of improvement.
- JAGUAR electric hoists are not designed for lifting people and should not be used for this purpose..

OPTIONAL

- Remote control for all models
- Stainless steel chains.
- Stainless steel rotary hook for models of 250kg 500kg and 1.000kg

**EC4 - 250 Kg. - 500 Kg.
1.000 Kg. - 3.000 Kg.
(schematic only)**

**EC4 - 2.000 Kg. - 5.000 Kg.
(schematic only)**

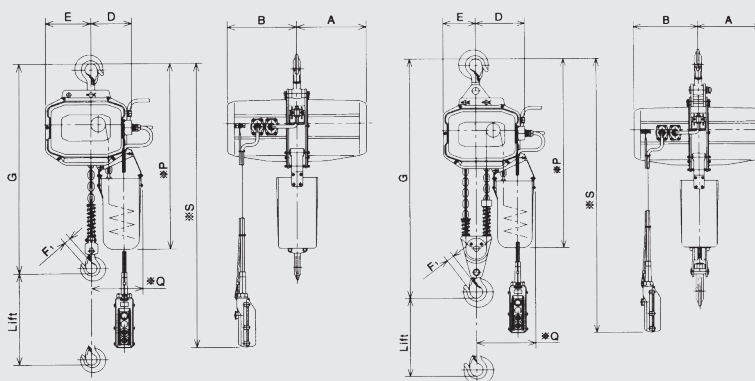

STANDARD SPECIFICATIONS: MOD. EC4, ELECTRIC HOIST ONE SPEED, THREE-PHASE, MONOTENSION

CODE	CAPACITY (Kg)	ELEVATION (m)	SPEED OF LIFTING (m/MINUTE)		POWER OF MOTOR ELEV. (KW)		SERVICE (MIN.)	CHAIN		HEIGHT (MAX.) G (mm)	TEST LOAD (Kg)	WEIGHT NET APPROX. (Kg)	MAIN DIMENSIONS (mm)						
			50 HZ	60 HZ	50 HZ	60 HZ		DIA. (MM.)	No. OF LEGS				A	B	D	E	F	P	Q
AE01000	250	3	8,7	10,3	0,4	0,5	30	6,3	1	485	315	35	245	245	137	149	20	660	195
AE02000	500	3	8,6	10,1	0,9	1,1		6,3	1	520	625	37	245	245	137	149	20	660	195
AE03000	1.000	3	5,6	6,6	1,1	1,3		7,1	1	570	1.250	49	255	255	150	180	25	710	200
AE04000	2.000	3	2,8	3,3	1,1	1,3		7,1	2	755	2.500	60	255	255	191	135	30	770	240
AE05000	3.000	4	4,4	5,2	2,5	3,0		11,2	1	765	3.750	106	335	335	195	135	36	950	235
AE06000	5.000	4	2,6	3,1	2,5	3,0		11,2	2	925	6.250	132	335	335	247	135	43	960	290

RECOMMENDED ACCESSORIES



MULTIPOSITION CLAMPS
BT MODEL
Pag. 48



SLING "DOL"
Pag. 84



SIMPLE POSITION CLAMPS
B MODEL
Pag. 47



CRANE SCALES
GPJ MODEL
Pag. 73