

COMPACT MODEL

SINGLE-PHASE ELECTRIC CHAIN HOISTS



The perfect tool for small and light assemblers.

Features:

- Two speeds
- Speed shifter via keypad.
- Up to 50 metres of chain.
- Aluminium body
- Load limiter.
- Heat protector.
- IP-54 protection of the motor, IP-65 protection of the keypad.

WITH SPEED CONTROLLER



Note: Includes transport case.

COMPACT - 024 (schematic only) **COMPACT - 048 (schematic only)**

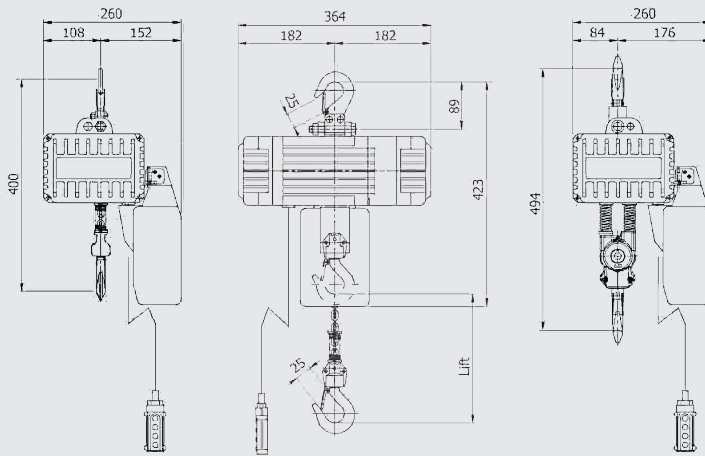

STANDARD SPECIFICATIONS: MOD. COMPACT

CODE	MODELO	CAPACITY (Kg)	LIFTING (m)	SPEED OF LIFTING (m/MINUTE)	POWER OF MOTOR. (W)	SERVICE (MIN.)	CHAIN (MIN.)	No. OF LEGS	NET WEIGHT APPROX. *(Kg)
ACOMP024	COMPACT - 024	240	3	0-3,2/12,5	600	15	4X12	1	16,5
ACOMP048	COMPACT - 048	480		0-1,6/6,3				2	19,4

RECOMMENDED ACCESSORIES



SLING "DOL"
Pag. 84



WEBBING SLINGS
Pag. 94



CRANE SCALES
GP-J MODEL
Pag. 73



TYPE B TROLLEY
SERIES 500
Pag. 22