

## BTX MODEL

### CLAMPS FOR STAINLESS STEEL PLATES

The multiposition clamp model "BTX" JAGUAR is manufactured for lifting plates and stainless steel structures.

- The minimum workload should not be less than 10% of the maximum workload.
- The lifting and opening capacity are laterally etched sideways on the body.

#### Features:

- The pivot segment and bolt are made up of stainless steel.
- The body and the safety mechanism are nickel plated to prevent corrosion from carbon pollution.

#### Note:

- The heavier the load, the stronger the grip.
- It is recommended to raise a single sheet at a time.
- If the load is bigger, at least two clamps with a two leg bridle sling should be used.

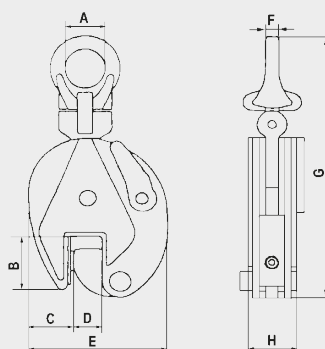
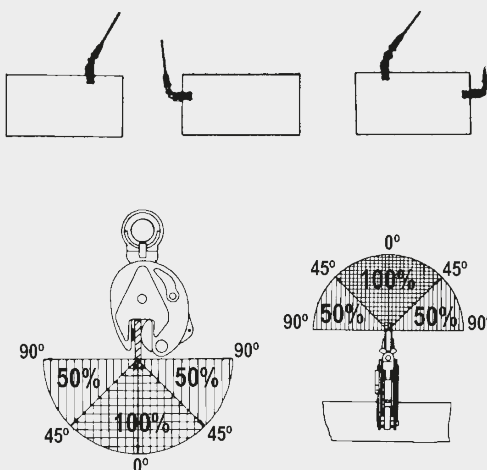

CODE	MODEL	MAX. WORK LOAD (KG)	FOR ROUNDED DIAMETER (mm)	MAIN DIMENSIONS (mm)								WEIGHT (Kg.)
				A	B	C	D	E	F	G	H	
AGUX20	BTX-20	2.000	0-35	70	78	56	0-35	183	16	425	56	72

#### RECOMMENDED ACCESSORIES



SLING "SO"  
Pag. 84

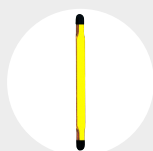

WEBBING SLINGS  
Pag. 94

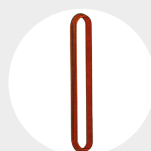

ROUND SLINGS  
Pag. 95

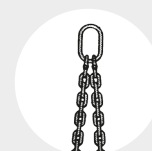

SLING "DO"  
Pag. 84