

BNM MODEL

NON MARKING CLAMPS



Features:

- The clamp "BNM" is a clamp with 2pads.
- The clamp can be used for lifting, handling and transporting (stainless) steel, aluminium, wood and marble slabs.
- After lifting and handling the clamp leaves no marks.
- The lifting and opening capacity are laterally etched sideways on the body.
- Its hasn't any minimum working load, the plate must be clean and dry.

Note:

The clamp is blocked both in open position as well as in a closed position.

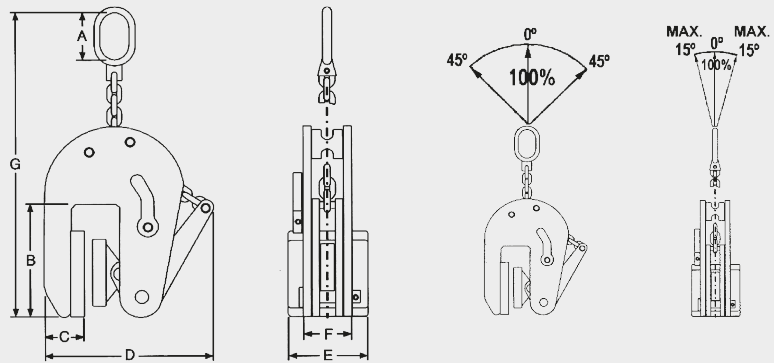

CODE	MODEL	MÁX. WORK LOAD (KG.)	OPENING CAPACITY (mm.)	MAIN DIMENSIONS (mm)							WEIGHT (Kg.)
				A	B	C	D	E	F	G	
AGNM05	BNM-05	500	0-20	70x38	103	48	177	80	48	435	5,7
AGNM051	BNM-051	500	17-37	79x39	103	48	187	80	48	455	6
AGNM10	BNM-10	1.000	0-30	79x39	103	46	195	80	52	447	6,5
AGNM20	BNM-20	2.000	0-50	99x49	123	63	260	80	65	670	14,2
AGNM30	BNM-30	3.000	0-60	99x49	123	63	260	80	65	650	14,2

RECOMMENDED ACCESSORIES



SLING "SO"
Pag. 84



WEBBING SLINGS
Pag. 94



ROUND SLINGS
Pag. 95



SLING "DO"
Pag. 84