

## B MODEL

### SIMPLE POSITION CLAMPS

The "B" model JAGUAR clamps is designed to vertically transport steel plates whilst total gripping force is maintained on the opening.

#### Features:

- The lever-activated safety closing device located on one side of the device makes it easier to grip the load easily.
- The lever, fitted with a strong spring, keeps the load blocked safely even when supported and there is no tension in the ring.
- The jaws are made of tempered steel, with a toothed surface. They grip the part to be transported in a positive and effective manner, thereby obtaining optimum results.
- The hardness of the steel plates to be lifted should not be higher than HRC 37 (HB-345).
- The minimum work load should not be lower than 10% of the maximum work load.
- The lifting capacity and opening are etched sideways on the body.

#### Note:

- If the load is big, it is best to use at least two clamps with a 2 leg bridle sling or with a lifting beam.
- It is recommended to lift a single sheet at a time.

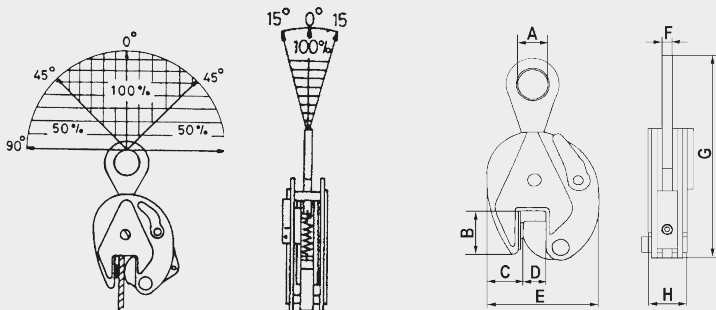

| CODE   | MODEL | MAX WORK LOAD (KG) | APERTURE CAPACITY (mm.) | MAIN DIMENSIONS (mm) |     |    |      |     |    |     |    | WEIGHT (Kg) |
|--------|-------|--------------------|-------------------------|----------------------|-----|----|------|-----|----|-----|----|-------------|
|        |       |                    |                         | A                    | B   | C  | D    | E   | F  | G   | H  |             |
| AGU050 | B-05  | 500                | 0-15                    | 30                   | 43  | 30 | 0-15 | 103 | 10 | 215 | 36 | 1,8         |
| AGU100 | B-10  | 1.000              | 0-20                    | 48                   | 63  | 51 | 0-20 | 138 | 14 | 290 | 55 | 4,2         |
| AGU200 | B-20  | 2.000              | 0-25                    | 70                   | 76  | 62 | 0-25 | 164 | 16 | 370 | 56 | 6,7         |
| AGU300 | B-30  | 3.000              | 0-30                    | 76                   | 85  | 56 | 0-30 | 193 | 20 | 430 | 78 | 14          |
| AGU500 | B-50  | 5.000              | 0-50                    | 80                   | 100 | 65 | 0-50 | 215 | 25 | 495 | 91 | 20,0        |

#### RECOMMENDED ACCESSORIES

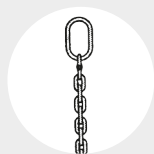

SLING "SO"  
Pag. 84



WEBBING SLINGS  
Pag. 94



ROUND SLINGS  
Pag. 95

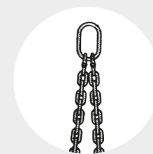

SLING "DO"  
Pag. 84