

ATACA MODEL

HEAVY MACHINERY ROLLER SKATES TROLLEYS

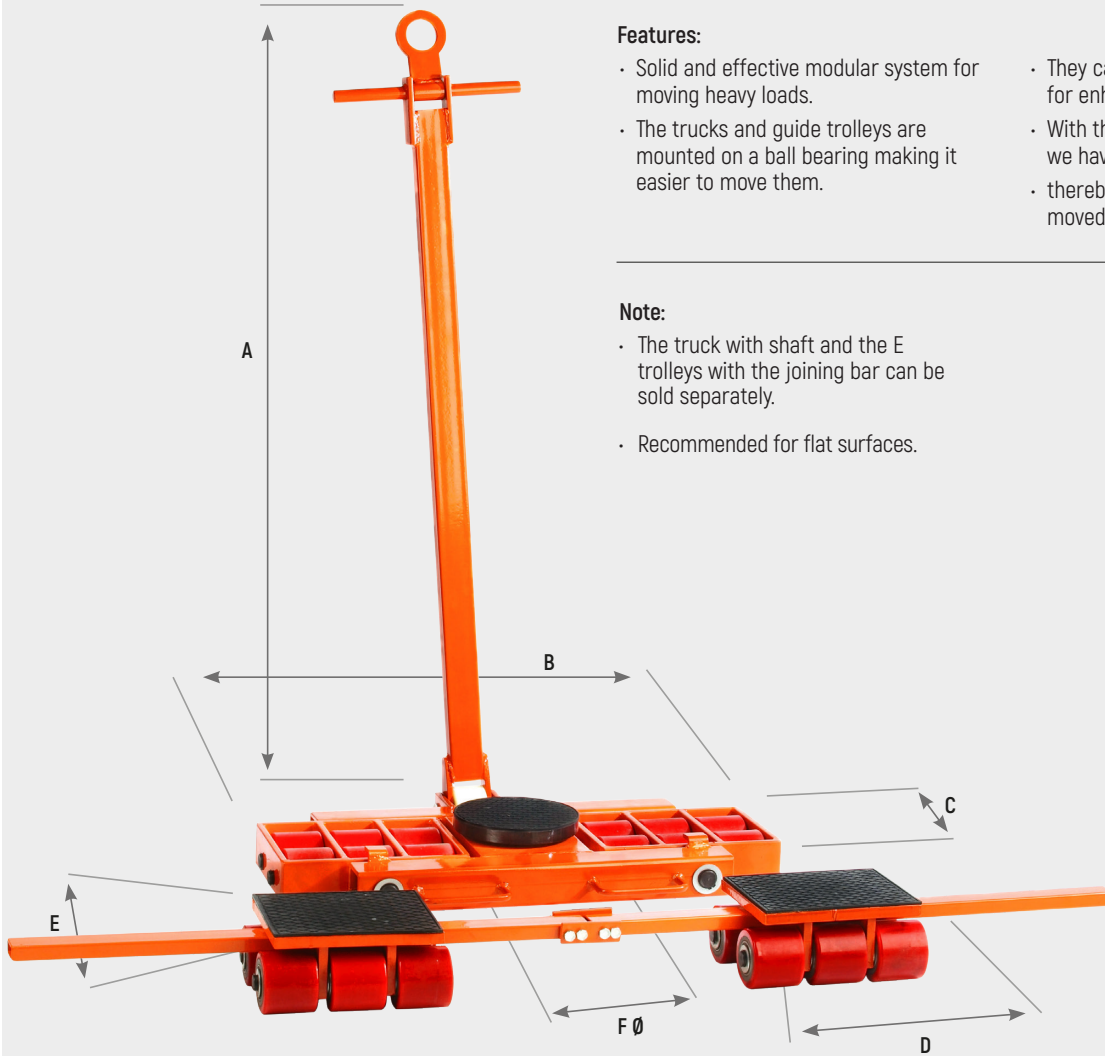

Features:

- Solid and effective modular system for moving heavy loads.
- The trucks and guide trolleys are mounted on a ball bearing making it easier to move them.
- They can be combined using joining bars for enhanced distribution of the load.
- With the wheels dimensions being 110mm we have a very low centre of gravity,
- thereby meaning that loads can be moved much more safely.

Note:

- The truck with shaft and the E trolleys with the joining bar can be sold separately.
- Recommended for flat surfaces.

CODE	CAPACITY (Kg)	HEIGHT	A	B	C	D	E	F Ø	NET WEIGHT (Kg)
ATACA 008	8.000	110	1.010	220	210	130	130	150	25
ATACA 012	12.000	110	1.010	220	210	200	175	150	30
ATACA 016	16.000	110	1.210	545	430	200	175	146	70
ATACA 020	20.000	110	1.210	545	430	270	180	145	83
ATACA 024	24.000	110	1.275	745	455	270	180	180	99
ATACA 030	30.000	110	1.275	745	455	256	300	180	117
ATACA 036	36.000	110	1.410	775	515	256	300	175	141

RECOMMENDED ACCESSORIES



HYDRAULIC TOE JACK
 MODEL AGATU
 Pag. 67



RACK JACK
 MODEL GC
 Pag. 66



LIFT LEVERS
 APAEL MODEL
 Pag. 70