

690 AT SERIES SPARK-PROOF HAND HOISTS



Suspension and load hook, guide rollers, rack wheel and copper-plated end of chain

Manufactured and marked according to ATEX Directive 2014/34/EU

High strength steel chain with Dacromet finish for increased durability against corrosion

Rustproof drive chain

The equipment is built to be marked Group II, Category 2, Temperature class T4, for use in the presence of gases and/or vapours of combustible liquids (G) of the IIC Group, with the aim that it can be located in ATEX zones such as ZONE 1. The equipment is therefore marked as follows
Ex II 2 G Ex h IIC T4 Gb.

This equipment is also built to be marked Group II, Category 2, Maximum Surface Temperature 120°C, for use in the presence of combustible dust (D), with the aim that it can be located in ATEX zones classified ZONE 21. The equipment will therefore be marked as follows
Ex II 2 D Ex h IIIB T135°C Db

Note:

JAGUAR differential pulleys are not designed for lifting people and must not be used for this purpose.

OPTIONAL:

- Rustproof load chain

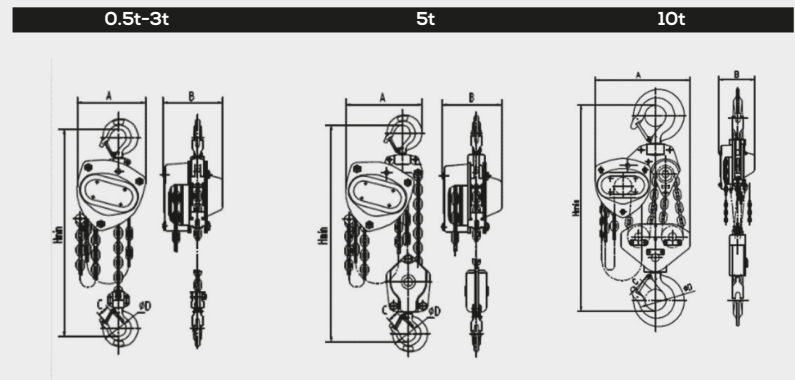

CODE	CAPACITY (kg)	No. LINKS	FORCE (N.)	WEIGHT WITH 3 m	MAX LIFTING WEIGHT (kg)	HOOK OPENING (mm)	DIMENSIONS			
							A	B	C	D
AFKAT2000	500	1	240	9	1,5	23	148	132	23	345
AFKAT3000	1.000	1	250	12	1,69	26	172	151	26	376
AFKAT5000	2.000	1	335	20	2,54	34	210	175	34	470
AFKAT6000	3.000	1	372	32	3,14	39	280	255	39	580
AFKAT8000	5.000	2	380	43	5,34	41	385	280	41	690
AFKAT11000	10.000	4	385	81	9,74	50	385	385	50	780

RECOMMENDED ACCESSORIES

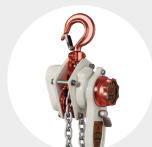

SPARK-PROOF LEVER HOISTS
990 AT SERIES
Pag. 30



SPARK-PROOF PULLEY-HOLDER TROLLEYS
590 AT SERIES
Pag. 29