

## ME MODEL

### SINGLE-PHASE MINI ELECTRIC WIRE HOISTS



#### ONE SPEED



It is a lightweight and compact device including two suspension accessories to be able to lock in both cylindrical tube and square. It can be easily adapted to the JAGUAR banner.

It is an ideal device for works in construction, agriculture, industry, etc.

#### Features:

- Cable guiding.
- Return hook to double the load capacity.
- 1.5.m keypad.

#### OPTIONAL

- Possibility to equip with banner.

#### IMPROVEMENTS

- 1 - Innovated system to avoid curling of the cable, without tension stops the process of winding the cable into the drum.
- 2 - Optional remote control.
- 3 - Steel end of run.
- 4 - Possibility of adapting to banner.
- 5 - Two coupling systems, for cylindrical Tube and for square tube.

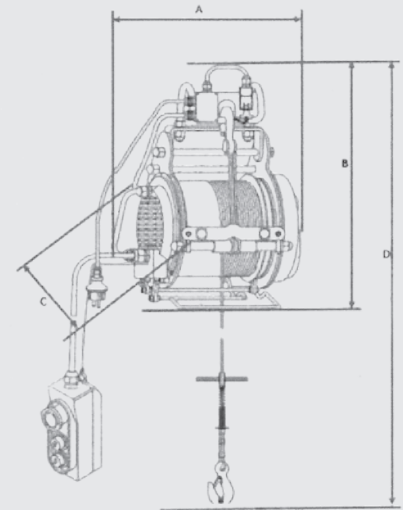

#### STANDARD SPECIFICATIONS

MODEL	CAPACITY (Kg)	SPEED OF LIFTING (m/MINUTE)	POWER OF MOTOR. (W)	CABLE LENGTH (NDS)
ME 250/500	250/500 (2)	8/4(2)	1.000	38/19(2)
ME 400/800	400/800 (2)	8/4(2)	1.300	32/16(2)

#### STANDARD SPECIFICATIONS: MOD. ME

	ME 250/500	ME 400/800
A	320	360
B	395	500
C	330	300
D	760	950
Peso	37,8	41

#### RECOMMENDED ACCESSORIES



SLING "DOL"  
Pag. 80



WEBBING SLINGS  
Pag. 90

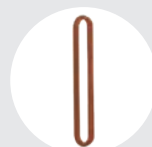

ROUND SLINGS  
Pag. 91