

ECT4 MODEL

TWO SPEED ELECTRIC CHAIN HOISTS

Two-speed electric hoists are manufactured for capacities ranging from 250 to 2000 Kg.

The ratio of 4 to 1 speed of the ECT4 model is the ideal for a wide variety of applications. At slow speed it works

accurately, moving the load to the position desired. At high speed the Load can be handled effectively and quickly.

For slow speed press the button halfway and for fast speed press the button completely.

Features:

- IP-54 protection of the motor, IP-65 protection of the keypad

Note:

- Make sure that the power, voltage and frequency are adequate.
- Design, materials and specifications are subject to change without prior Notification for reasons of improvement.
- JAGUAR electric hoists are not designed for lifting people and should not be used for this purpose.

OPTIONAL

- Remote control for all models
- Stainless steel chains.
- Stainless steel rotary hook for models of 250 kg, 500 kg and 1000kg.

TWO SPEEDS



ECT4 500 kg.

ECT4 · 250 Kg. - 1.000 Kg.
(schematic only)

ECT4 · 2.000 Kg.
(schematic only)

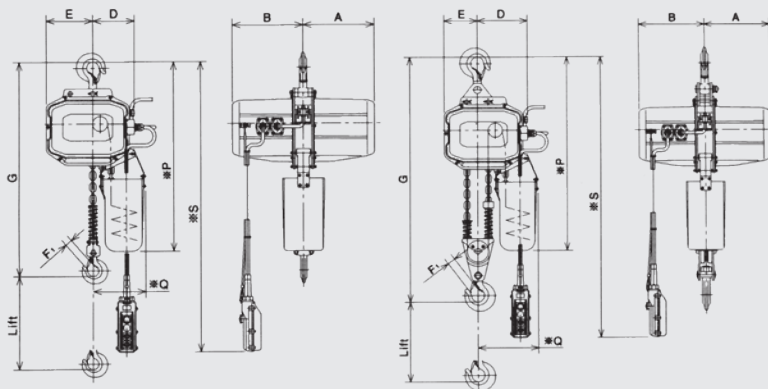

STANDARD SPECIFICATIONS: MOD. ECT4, ELECTRIC HOIST TWO SPEEDS, THREE-PHASE, MONOTENSION

CAPA-	ELEVA-	SPEED LIFTING				POWER OF MOTOR ELEV.				SERVICE		CHAIN		HEIGHT	LOAD	WEIGHT	MAIN DIMENSIONS (mm)							
		FAST		SLOW		FAST		SLOW		FAST	LENTO	DIA. (mm.)	No. OF				A	B	D	E	F	P	Q	
		50 HZ	60 HZ	50 HZ	60 HZ	50 HZ	60 HZ	50 HZ	60 HZ															
250	3	8,7	10,3	2,2	2,6	0,4	0,5	0,10	0,13	30	10	6,3	1	485	315	35	245	245	137	149	20	660	195	
500		8,6	10,1	2,2	2,6	0,9	1,1	0,23	0,28			6,3	1	520	625	37	245	245	137	149	20	660	195	
1.000		5,6	6,7	1,4	1,7	1,1	1,3	0,27	0,33			7,1	1	570	1.250	49	255	255	150	180	25	710	200	
2.000		2,8	3,3	0,7	0,8	1,1	1,3	0,27	0,33			7,1	2	755	2.500	60	255	255	191	135	30	770	240	

RECOMMENDED ACCESSORIES

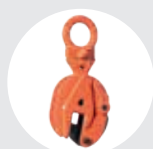

MULTIPOSITION CLAMPS
BT MODEL
Pag. 36



SLING "DOL"
Pag. 80

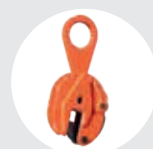

SIMPLE POSITION CLAMPS
B MODEL
Pag. 37



CRANE SCALES
GPJ MODEL
Pag. 70