

# ECH4 MODEL

## ONE SPEED ELECTRIC CHAIN HOISTS

### ONE SPEED



ECH4  
1.000 kg.

### Features:

- IP-54 protection of the motor, IP-65 protection of the keypad.

### OPTIONAL

- Remote control for all models
- Stainless steel chains.
- Stainless steel rotary hook for 500 Kg and 1000 Kg models

### Note:

- Make sure that the power, voltage and frequency are adequate.
- Design, materials and specifications are subject to change without prior Notification for reasons of improvement.
- JAGUAR electric hoists are not designed for lifting people and should not be used for this purpose.

**ECH4 · 500 Kg - 1.000 Kg**  
(schematic only)

**ECH4 · 2.000 Kg**  
(schematic only)

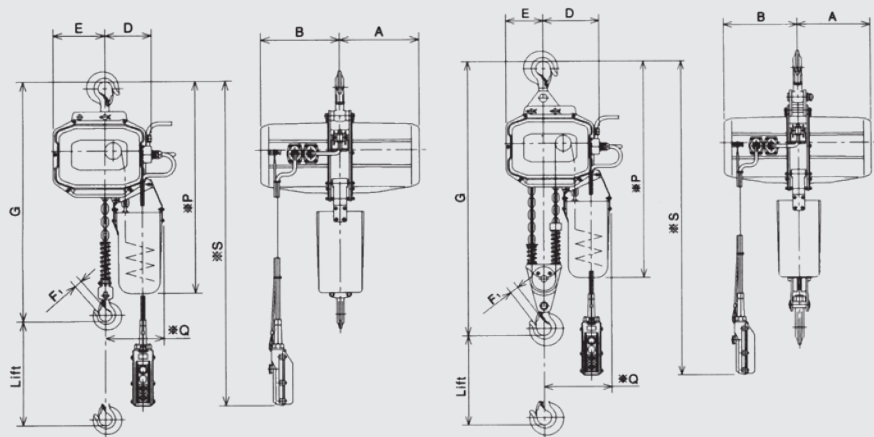

### STANDARD SPECIFICATIONS: MOD. ECH4, ELECTRIC HOIST ONE SPEED, THREE-PHASE, MONOTENSION

CAPACITY (Kg)	LIFTING (m)	SPEED OF LIFTING (m/MINUTE)	POWER OF MOTOR ELEV. (KW)	SERVICE (MIN.)	CHAIN		HEIGHT (MAX.) G (mm)	WEIGHT NET APPROX. (Kg)	TEST LOAD (Kg)	MAIN DIMENSIONS (mm)						
		50 HZ	50 HZ		DIA. (mm.)	N° OF LEG				A	B	D	E	F	P	Q
500		6,3	0,8			1	600	60	625	168	160	25	670	195		
1.000	3	6,3	1,6	30	7,1	1	600	63	1.250	249	168	160	30	670	195	
2.000		3,2	1,6			2	760	70	2.500	180	134	33	750	235		

### RECOMMENDED ACCESSORIES

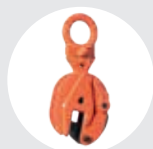

**MULTIPOSITION CLAMPS**  
BT MODEL  
Pag. 36



**SLING "DOL"**  
Pag. 80



**SIMPLE POSITION CLAMPS**  
B MODEL  
Pag. 37



**CRANE SCALES**  
GPJ MODEL  
Pag. 70