

ECCH4 MODEL

SINGLE PHASE 220V. ELECTRIC CHAIN HOISTS

Features:

- IP-54 protection of the motor, IP-65 protection of the keypad.

OPTIONAL

- Remote control for all models
- Stainless steel chains.
- Stainless steel rotary hook for models of 500 kg and 1000 kg.

Note:

- a) a) Make sure that the power, voltage and frequency are adequate.
- b) Design, materials and specifications are subject to change without prior notification for reasons of improvement.
- c) JAGUAR electric hoists are not designed for lifting people and should not be used for this purpose.

ONE SPEED



ECCH4
1.000 kg.

ECCH4 · 500 Kg - 1000 Kg.
(schematic only)

ECCH4 · 2.000 Kg
(schematic only)

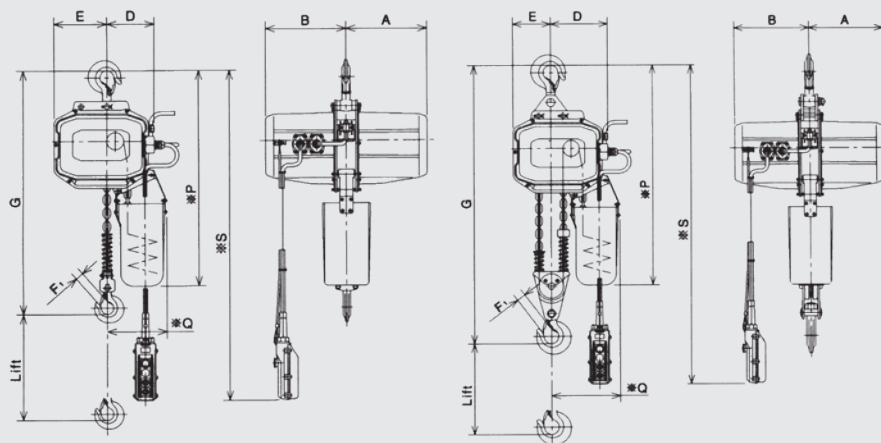

STANDARD SPECIFICATIONS: MOD. ECCH4, ELECTRIC HOIST ONE SPEED, SINGLE-PHASE, MONOTENSION

CAPACITY (Kg)	LIFTING (m)	SPEED OF LIFTING (m/MINUTE)	POWER OF MOTOR ELEV. (KW)	SERVICE (MIN.)	CHAIN		HEIGHT (MAX.) G (mm)	WEIGHT NET APPROX. (Kg)	TEST LOAD (Kg)	MAIN DIMENSIONS (mm)								
		50 HZ	50 HZ		DIA. (mm.)	No OF LEG				A	B	D	E	F	P	Q		
500		5,2	0,8			1	620	60	625	168	146	25	670	195				
1.000	3	5,2	1,2	30	7,1	1	600	63	1.250	249	168	146	30	670	195			
2.000		2,6	1,2			2	760	70	2.500	180	134	33	750	235				

RECOMMENDED ACCESSORIES

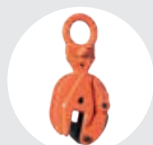

MULTIPOSITION CLAMPS
BT MODEL
Pag. 36



SLING "DOL"
Pag. 80



SIMPLE POSITION CLAMPS
B MODEL
Pag. 37



CRANE SCALES
GPJ MODEL
Pag. 70