

# ECE4 - ECTE4 MODELS

## ELECTRIC CHAIN HOISTS WITH ELECTRIC TROLLEY

### Features:

- IP-54 protection of the motor, IP-65 protection of the keypad.

### OPTIONAL

- Remote control for all models
- Stainless steel chains.
- Stainless steel rotary hook for models of 250 kg, 500 kg and 1000kg.

### ONE OR TWO SPEEDS

**ECE4 - ECTE4 · 250 Kg - 500 Kg.  
- 1000 Kg - 3000 Kg.  
(schematic only)**

Electric chain hoists with electric trolley with one or two speeds.

**ECE4 - ECTE4 · 2.000 Kg - 5.000 Kg  
(schematic only)**

Electric chain hoists with electric trolley with one or two speeds.

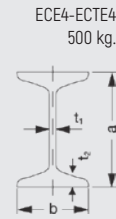
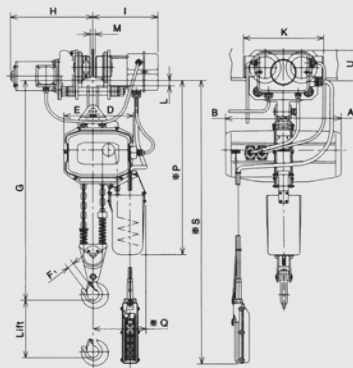
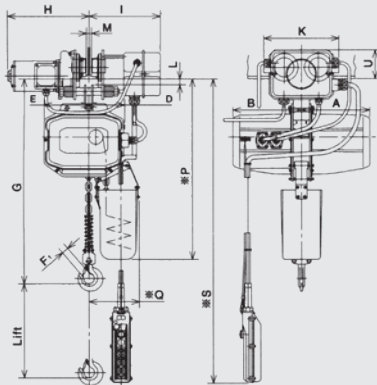

SPECIFICATIONS ONE LIFTING SPEED								
CAPACITY (Kg)	LIFTING (m.)	SPEED LIFTING (m/MINUTE)		POWER OF MOTOR ELEV. (KW)		SERVICE (MIN.)	CHAIN	
		50 HZ	60 HZ	50 HZ	60 HZ		DIA. (mm.)	No. OF LEGS
250	3	8,7	10,3	0,4	0,5	30	6,3	1
500	3	8,6	10,1	0,9	1,1		6,3	1
1.000	3	5,6	6,6	1,1	1,3		7,1	1
2.000	3	2,8	3,3	1,1	1,3		7,1	2
3.000	4	4,4	5,2	2,5	3,0		11,2	1
5.000	4	2,6	3,1	2,5	3,0	11,2	2	

SPECIFICATIONS TWO LIFTING SPEEDS													
CAPACITY (KGS.)	ELEVACIÓN (M.)	SPEED LIFTING (m/MINUTE)				POWER OF MOTOR ELEV. (KW)				SERVICE (MIN.)		CHAIN	
		FAST		SLOW		FAST		SLOW		FAST-SLOW	DIA. (mm.)	No. OF LEGS	
		50 HZ	60 HZ	50 HZ	60 HZ	50 HZ	60 HZ	50 HZ	60 HZ				
250	3	8,7	10,3	2,2	2,6	0,4	0,5	0,10	0,13	30	10	6,3	1
500		8,6	10,1	2,2	2,6	0,9	1,1	0,23	0,28			6,3	1
1.000		5,6	6,7	1,4	1,7	1,1	1,3	0,27	0,33	7,1	1		
2.000		2,8	3,3	0,7	0,8	1,1	1,3	0,27	0,33	7,1	2		

### STANDARD SPECIFICATIONS: MOD. ECP4 - ECTP4, HOISTS WITH ELECTRIC PUSH TROLLEY, ONE OR TWO SPEEDS, THREE-PHASE, MONOTENSION.

CAPACITY (Kg)	VEL. DEL CARRO (M/MINUTO)		POTENCIA MOTOR CARRO (KW.)	SERVICE (MIN.)	WIDTH OF BEAM B(mm)	MÍNIMO RADIO DE CURVA (M.)	HEIGHT MAX. G (mm)	WEIGHT NET APPROX. (Kg)	MAIN DIMENSIONS (mm)											
	50 HZ	60 HZ							A	B	D	E	F1	H	I	K	L	M	*P	*Q
250			0,2	30	58-125	1,0	495	62	245	245	137	149	20	b/2 +280	b/2 +240	240	32-t	b-49	670	195
500			0,2		58-125	1,0	530	65	245	245	137	149	20	b/2 +280	b/2 +240	240	32-t	b-49	670	195
1.000	20	24	0,2		58-125	1,0	565	80	255	255	150	168	25	b/2 +208	b/2 +240	240	32-t	b-49	705	200
2.000			0,4		75-155	1,0	820	110	255	255	191	140	30	b/2 +325	b/2 +250	360	33-t	b-70	790	220
3.000			0,4		95-185	1,5	805	176	350	335	195	150	36	b/2 +330	b/2 +240	390	37-t	b-76	920	235
5.000	10	12	0,75	95-185	1,5	975	229	350	300	247	93	43	b/2 +330	b/2 +245	434	38-t	b-80	1.010	290	

OPTIONAL: Trolley speed 10 metres/minute for capacities from 250 to 3000.

### RECOMMENDED ACCESSORIES

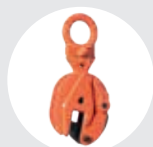

**MULTIPOSITION CLAMPS  
BT MODEL**  
Pag. 36



**SLING "DOL"**  
Pag. 80

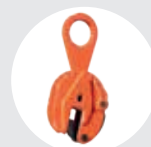

**SIMPLE POSITION CLAMPS  
B MODEL**  
Pag. 37



**CRANE SCALES  
GPJ MODEL**  
Pag. 70