

ECGH4 - ECPH4 MODELS

ELECTRIC CHAIN HOISTS WITH GEARED OR PUSH TROLLEY

Features:

- IP-54 protection of the motor, IP-65 protection of the keypad.

OPTIONAL

- Remote control for all models
- Stainless steel chains.
- Stainless steel rotary hook for models of 500 kg and 1000 kg.

Note:

- Make sure that the power, voltage and frequency of the network are correct.
- The dimensions marked * in the table above they vary according to different elevations.
- Design, materials and specifications are subject to change without prior notification for reasons of improvement.
- JAGUAR electric hoists are not designed for lifting people and should not be used for this purpose.

ONE SPEED



ECGH4 · 500 Kg - 2000 Kg.
(schematic only)
Electric chain hoists with geared trolley with one speed.

ECPH4 · 500 Kg - 2000 Kg.
(schematic only)
Electric chain hoists with push trolley with one speed.

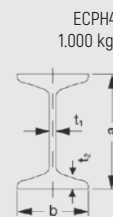
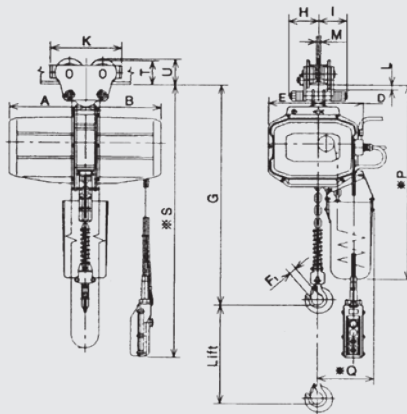
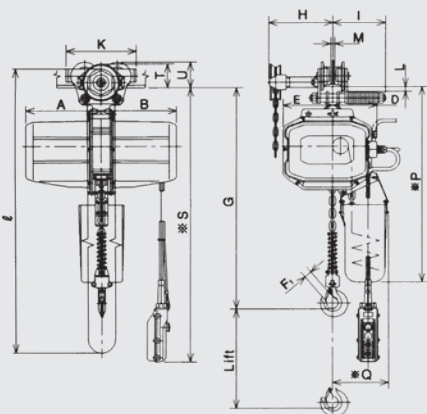

STANDARD SPECIFICATIONS

CAPACITY (Kg)	LIFTING (m)	SPEED OF LIFTING (m/MINUTE)		POWER OF MOTOR ELEV. (KW)	SERVICE (MIN.)
		50 HZ	50 HZ		
500	3	6,3	0,8	30	
1.000		6,3	1,6		
2.000		3,2	1,6		

STANDARD SPECIFICATIONS: MOD. ECGH4, ELECTRIC CHAIN HOISTS WITH TROLLEY CHAIN ECPH4, ELECTRIC HOISTS WITH PUSH TROLLEY, ONE SPEEDS, THREE-PHASE, MONOTENSION.

CAPACITY (Kg)	ECGH4 - ECPH4													ECGH4		ECPH4			
	WIDTH OF BEAM B(mm)	MINIMUM RADIUS (m)	HEIGHT (MAX.) G (mm)	MAIN DIMENSIONS (mm)										H (MM.)	LEN. CHAIN (m.)	WEIGHT NET APPROX. *(Kg)	H (mm.)	WEIGHT NET APPROX. *(Kg)	
				A	B	D	E	F1	I	K	L	M	*P						*Q
500	50-140	1	680			168	146	25	105	206				650	195	b/2 +275	78	b/2 +115	65
1.000	58-140	1,5	730	249		168	146	30	105	206	24-t2	b-42	650	195	b/2 +280	3	84	b/2 +130	77
2.000	74-165	2	855			180	134	33	128	270			815	235	b/2 +285	101	b/2 +145	83	

RECOMMENDED ACCESSORIES

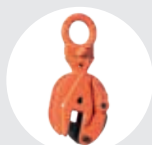

MULTIPOSITION CLAMPS
BT MODEL
Pag. 36



SLING "DOL"
Pag. 80

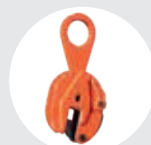

SIMPLE POSITION CLAMPS
B MODEL
Pag. 37



CRANE SCALES
GPJ MODEL
Pag. 70