

# ECCPH4 - ECCGH4 MODELS

SINGLE PHASE ELECTRIC CHAIN HOISTS WITH GEARED OR PUSH TROLLEY

**ONE SPEED**

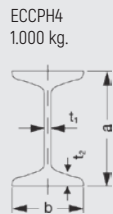

**Features:**

- IP-54 protection of the motor, IP-65 protection of the keypad.

**OPTIONAL**

- Remote control for all models
- Stainless steel chains.
- Stainless steel rotary hook for models of 500 kg and 1000 kg.

**Note:**

- a) Make sure that the power, voltage and frequency of the network are correct.
- b) The dimensions marked \* in the table above they vary according to different elevations.
- c) Design, materials and specifications are subject to change without prior notification for reasons of improvement.
- d) JAGUAR electric hoists are not designed for lifting people and should not be used for this purpose.

**ECCGH4 · 500 Kg - 2000 Kg.**  
(schematic only)  
Electric chain hoists with single-phase electric trolleys

**ECCPH4 · 500 Kg - 2000 Kg.**  
(schematic only)  
Electric chain hoists with single-phase push trolleys

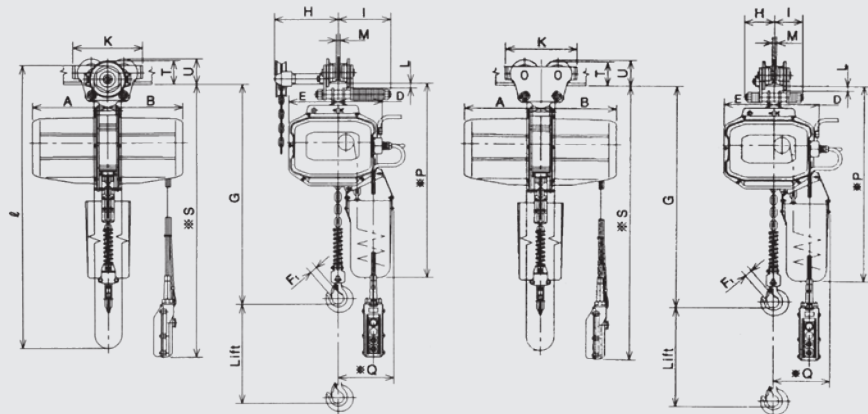

**STANDARD SPECIFICATIONS**

CAPACITY (Kg)	LIFTING (m)	SPEED OF LIFTING (m/MINUTE)		POWER OF MOTOR ELEV. (KW)		SERVICE (MIN.)	CHAIN	
		50 HZ	50 HZ	50 HZ	50 HZ		DIA. (mm.)	No OF LEG
500	3	5,2	0,8	30	7,1	1		
1.000		5,2	1,2				1	
2.000		2,6	1,2				2	

**STANDARD SPECIFICATIONS: MOD. ECCGH4, ELECTRIC CHAIN HOISTS WITH TROLLEY CHAIN. ECCPH4, ELECTRIC HOISTS WITH PUSH TROLLEY, ONE SPEEDS, THREE-PHASE, MONOTENSION.**

CAPACITY (Kg)	ECCGH4 / ECCPH4													ECCGH4			ECCPH4			
	WIDTH OF BEAM B(mm)	MINIMUM RADIUS (m)	HEIGHT (MAX.) G (mm)	MAIN DIMENSIONS (mm)										H (mm.)	LEN. CHAIN. (m.)	WEIGHT NET APPROX. *(Kg)	H (mm.)	WEIGHT NET APPROX. *(Kg)		
				A	B	D	E	F1	I	K	L	M	*P						*Q	
500	50-140	1	680			168	146	25	105	206					650	195	b/2 +275	78	b/2 +115	71
1.000	58-140	1,5	730	249		168	146	30	105	206	24-t2	b-42		650	195	b/2 +280	3	84	b/2 +130	77
2.000	74-165	2	855			180	134	33	128	262				685	235	b/2 +285	101	b/2 +145	94	

**RECOMMENDED ACCESSORIES**

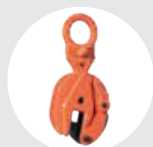

**MULTIPOSITION CLAMPS**  
BT MODEL  
Pag. 36



**SLING "DOL"**  
Pag. 80



**SIMPLE POSITION CLAMPS**  
B MODEL  
Pag. 37



**CRANE SCALES**  
GPJ MODEL  
Pag. 70