

ECCEH4 MODEL

SINGLE PHASE ELECTRIC CHAIN HOISTS WITH ELECTRIC TROLLEY

Features:

- IP-54 protection of the motor, IP-65 protection of the keypad.

OPTIONAL

- Remote control for all models
- Stainless steel chains.
- Stainless steel rotary hook for models of 500 kg and 1000 kg.

Note:

- a) Make sure that the power, voltage and frequency of the network are correct.
- b) The dimensions marked * in the table above they vary according to different elevations.

c) Design, materials and specifications are subject to change without prior notification for reasons of improvement.

d) JAGUAR electric hoists are not designed for lifting people and should not be used for this purpose.

ONE SPEED



ECCEH4 · 500 Kg - 1000 Kg. (schematic only) **ECCEH4 · 2000 Kg. (schematic only)**

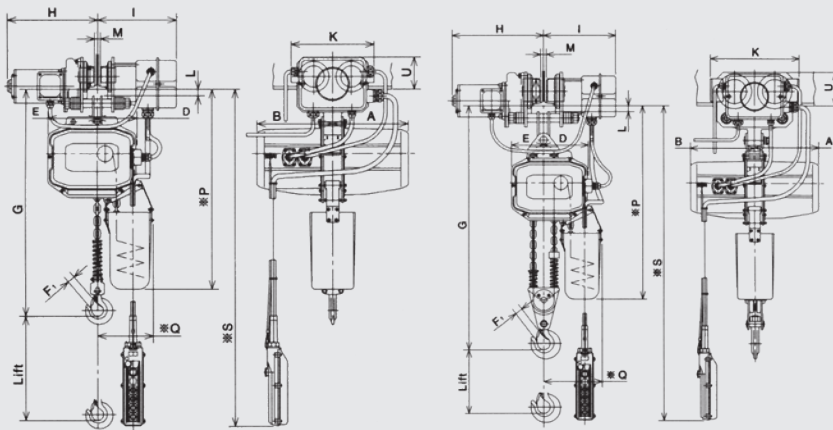

STANDARD SPECIFICATIONS

CAPACITY (Kg)	LIFTING (m)	SPEED OF LIFTING (m/MINUTE)		POWER OF MOTOR ELEV. (KW)	SERVICE (MIN.)	CHAIN	
		50 HZ	50 HZ			DIA. (mm.)	No OF LEG
500	3	5,2	0,8	30	7,1	1	
1.000		5,2	1,2				
2.000		2,6	1,2				

STANDARD SPECIFICATIONS: MOD. ECCEH4, HOIST WITH ELECTRIC TROLLEY, ONE SPEED, SINGLE-PHASE, MONOTENSION

CAPACITY (Kg)	VEL. DEL CARRO (M./MINUTO)	POT. MOTOR CARRO (KW)	SERVICE (MIN.)	WIDTH OF BEAM B(mm)	MÍNIMO RADIO DE CURVA (M.)	HEIGHT (MAX.) G (mm)	WEIGHT NET APPROX. (Kg)	MAIN DIMENSIONS (mm)										
	50 HZ							A	B	D	E	F1	H	I	K	L	M	*P
500	20	0,3	30	75-180	1,0	700	103	30					120 40 750					
1.000								220	140	170	30	320	200	270	120	40	750	300
2.000								35					110 30 700					

RECOMMENDED ACCESSORIES

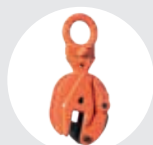

MULTIPOSITION CLAMPS
BT MODEL
Pag. 36



SLING "DOL"
Pag. 80



SIMPLE POSITION CLAMPS
B MODEL
Pag. 37



CRANE SCALES
GPJ MODEL
Pag. 70