

CH4 AND CCH4 MODELS

ELECTRIC TROLLEY THREE-PHASE AND SINGLE-PHASE



ONE SPEED

The CH4 and CCH4 models are electric trolley models that have a shaft with a very useful recess to place any hook and so is able to transport any kind of material using a beam.

Features:

- Three-phase and single-phase voltage (50 Hz).
- Possibility of adapting to IPE, IPN, HEB... Opening range 75-180 mm.
- Possibility of modifying the length of the keypad.
- Keypad with four buttons plus emergency stop.
- Low voltage control 24v.
- P-54 protection of the motor, IP-65 protection of the keypad.

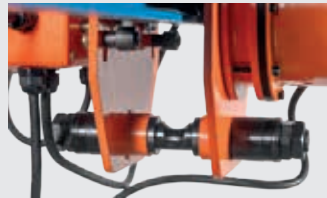

CH4 (schematic only) **CCH4 (schematic only)**

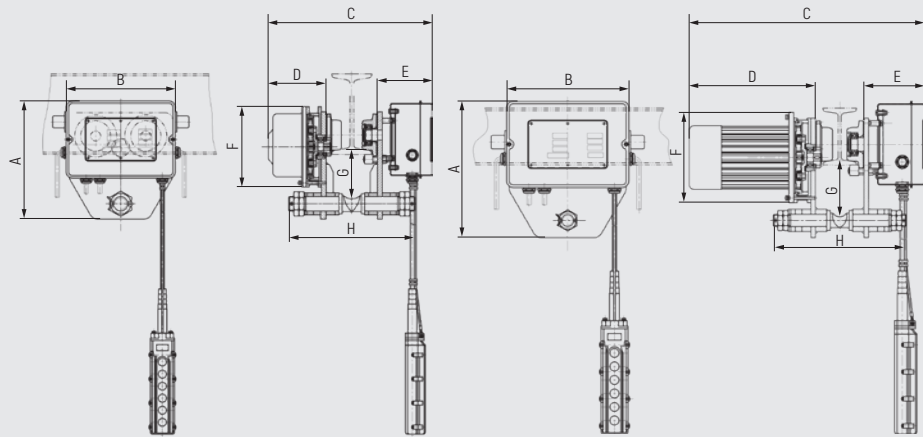

STANDARD SPECIFICATIONS																
MODEL	MAX. WORKING LOAD (Kg)	SPEED OF TROLLEY (m/MINUTE) 50Hz	VOLTAGE	LENGTH STANDARD OF CABLE (METRES)	SERVICE (MIN.)	WIDTH OF BEAM (mm)	RADIUS MINIMUM OF CURVE (m)	WEIGHT NET APPROX.	MAIN DIMENSIONS (mm)							
									A	B	C	D	E	F	G	H
CH-4	1.000	20	THREE-PHASE	3	30	75-180	1,0	35	303	272	390	144	140	200	125	290
CH-4	2.000	20	THREE-PHASE	3	30	75-180	1,0	39	303	272	410	144	142	200	125	311
CCH-4	1.000	20	SINGLE-PHASE	3	30	75-180	1,0	40	303	272	540	281	156	200	125	295
CCH-4	2.000	20	SINGLE-PHASE	3	30	75-180	1,0	44	303	272	549	283	162	200	125	311

RECOMMENDED ACCESSORIES



HAND CHAIN HOISTS
SERIES 630
Pag. 20



ELECTRIC CHAIN HOISTS
ECH4 MODEL
Pag. 110