

# ECEH4 MODEL

ELECTRIC CHAIN HOISTS WITH ELECTRIC TROLLEY

**ONE SPEED**

**Features:**

- IP-54 protection of the motor, IP-65 protection of the keypad.

**OPTIONAL**

- Remote control for all models
- Stainless steel chains.
- Stainless steel rotary hook for models of 500 kg and 1000 kg.

**Note:**

- a) Make sure that the power, voltage and frequency of the network are correct.
- b) The dimensions marked \* in the table above they vary according to different elevations.
- c) Design, materials and specifications are subject to change without prior notification for reasons of improvement.
- d) JAGUAR electric hoists are not designed for lifting people and should not be used for this purpose.

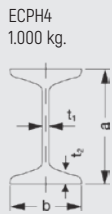

**ECEH4 - 500 Kg. - 1.000 Kg.**  
(schematic only)

**ECEH4 - 2.000 Kg.**  
(schematic only)

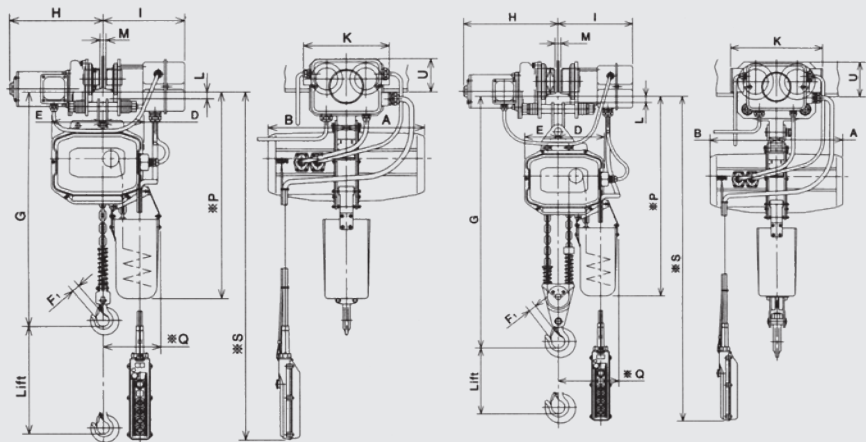

**STANDARD SPECIFICATIONS**

CAPACITY (Kg)	LIFTING (m)	SPEED OF LIFTING (m/MINUTE)		POWER OF MOTOR ELEV. (KW)	SERVICE (MIN.)
		50 HZ	50 HZ		
500	3	6,3	0,8	30	
1.000		6,3	1,6		
2.000		3,2	1,6		

**STANDARD SPECIFICATIONS: MOD. ECEH4, HOIST WITH ELECTRIC TROLLEY, ONE SPEED, THREE-PHASE, MONOTENSION**

CAPACITY (Kg)	SPEED OF TROLLEY (M./MINUTE)	POWER OF MOTOR TROLLEY (KW)	SERVICE (MIN.)	WIDTH OF BEAM B(mm)	MINIMUM RADIUS (M.)	HEIGHT (MAX.) G (mm)	WEIGHT NET APPROX. (Kg)	MAIN DIMENSIONS (mm)												
								A	B	D	E	F1	H	I	K	L	M	*P	*Q	
500	20	0,3	30	75-180	1,0	630	95	168	146	25								b-50	730	195
1.000								249	168	146	30	170	200	270	110	b-50	730	195		
2.000								180	134	33							b-50	775	235	

**RECOMMENDED ACCESSORIES**

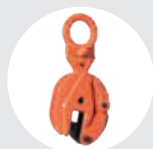

**MULTIPOSITION CLAMPS**  
BT MODEL  
Pag. 36



**SLING "DOL"**  
Pag. 80

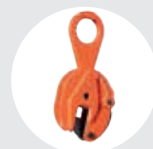

**SIMPLE POSITION CLAMPS**  
B MODEL  
Pag. 37



**CRANE SCALES**  
GPJ MODEL  
Pag. 70