



TA MODEL WALL WINCHES



Wall winches are equipped with a handle for lifting and lowering easily. The brake is continuously applied, this way the risk of the load suddenly dropping is removed. The new anti-corrosive finish extends the life of the equipment, including outdoors.

Main features:

- Total safety both for lifting and lowering, thanks the endless screw system that makes it possible for the load to remain suspended. If the handle is not being used, the brake is fully applied.
- Allows for the addition of cable according to needs.

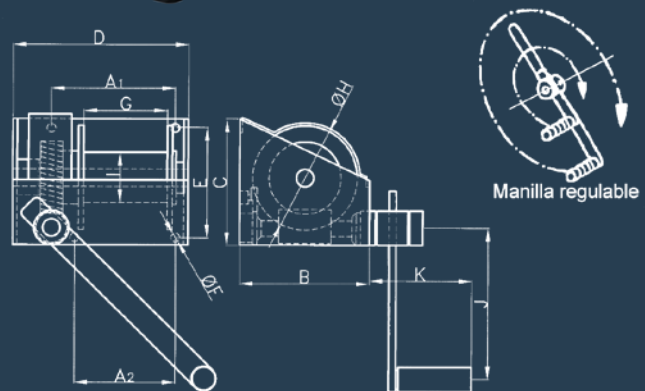

MODEL	LOAD MAX. OF WORK (Kg)	MAIN DIMENSIONS (mm)											DIAMETER OF CABLE RECOMMENDED (mm)	CAPACITY OF CABLE IN METRES	FORCE OF THE CRANK (Kg)	WEIGHT APPROX. (Kg)	
		A1	A2	B	C	D	E	F	G	H	I	J					K
TA-25	250	137	100	149	152	199	117	11	95	118	58	250	180	6	20	12	10
TA-50	500	182	130	181	181	260	140	13	148	150	69	255	180	7	25	13	15,3
TA-100	1.000	167	165	280	300	300	248	17	158	244	100	375	210	9	35	14	29,5
TA-200	2.000	258	220	340	340	395	295	22	233	285	130	380	194	13	30	22	70

RECOMMENDED ACCESSORIES



SWIVEL SLING HOOK WITH LATCH
Pag. 76

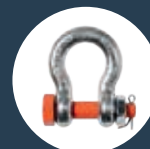

SHACKLES
Pag. 94

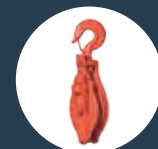

SNATCH BLOCKS PBG MODELS
Pag. 30