

BL MODEL

BLOCK CLAMPS

Features:

- The JAGUAR clamp model "BL" is manufactured for vertical lift and transport of different products with parallel sides without damaging or marking the product, valid for all types of materials such as steel, wood, plastic, concrete, marble, etc.
- The clamp is blocked in an open position.
- For the lifting, the operator must operate the lever and hold it upward until the eyebolt rise. When positioning the load on the ground, the clamp releases the load automatically.
- The minimum workload should not be less than 10% of the maximum workload.

Note:

The clamps are coated with a special plastic that prevents damage or marking the load.

For correct operation, the sides of the load must be parallel.

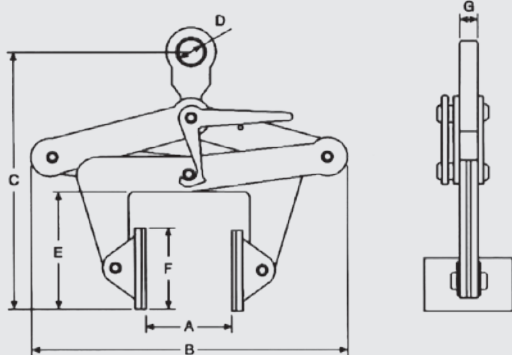

MODEL	MÁX. WORK LOAD (Kg.)	OPENING (mm.)	MAIN DIMENSIONS (mm)						WEIGHT (Kg.)
			A	B	C	D	E	F	
BL-05	500	30-110	30-110	275-325	270-420	45	100	70x80	6,5
BL-10	1.000	100-230	100-230	440-530	360-610	45	140	100x120	13
BL-20	2.000	220-360	220-360	600-675	400-680	45	170	100x120	18
BL-30	3.000	350-500	350-500	740-840	490-840	65	200	100x120	32

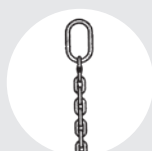

SLING "SO"
Pag. 80



WEBBING SLINGS
Pag. 90



ROUND SLINGS
Pag. 91



FORKLIFT HOOK
UCAR MODEL
Pag. 56