

# GBID MODEL

## DRUMS HOOKS

**Features:**

- Drum hooks along with chain slingallows transporting drumshorizontally.

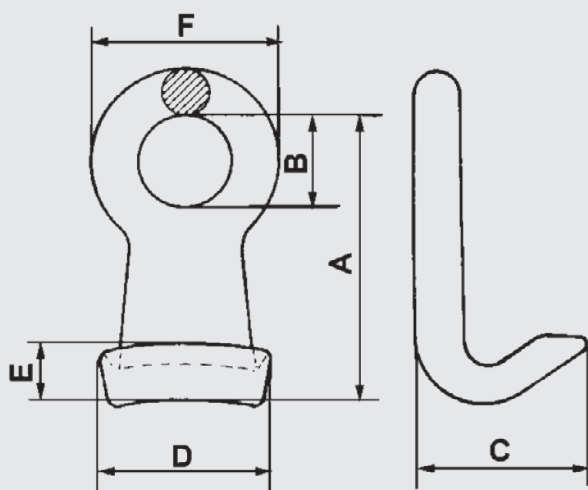

MODELO	MAX. WORK PAIR LOAD	PAIR WEIGHT (Kg.)	MAIN DIMENSIONS (mm)					
			A	B	C	D	E	F
GBID10	1 Ton.	12	109	38	55	60	29	65



**FORKLIFT HOOK**  
UCAR MODEL  
Pag. 56

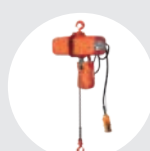

**THREE-PHASE CHAIN**  
EC4 MODEL  
Pag. 106

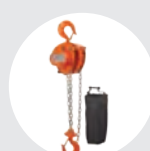

**HAND CHAIN HOISTS**  
SERIES 630  
Pag. 20