



NOVEDADES

ACCESORIOS Y
ESLINGAS

G60



INOXIDABLE

NOVEDADES

CADENA
ACERO INOXIDABLE
G60

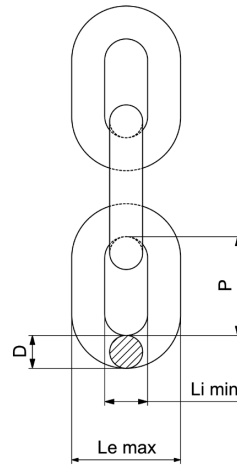

CODIGO	MEDIDA (MM.)	C.M.T. (TON.)	PRINCIPALES DIMENSIONES (MM)				PESO (KGS.)
			P	D	L MIN	L MAX	
PHCI1000	6-6	0.9	18	6	7.8	22.2	0.80
PHCI1500	7-6	1.25	21	7	9.1	25.9	1.10
PHCI2000	8-6	1.6	24	8	10.4	29.6	1.40
PHCI3000	10-6	2.5	30	10	13	37	2.20

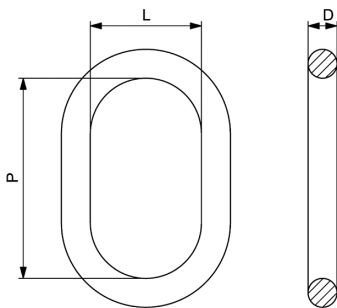

NOVEDADES

ANILLA OVALADA EN
ACERO INOXIDABLE
G60

CODIGO	MODELO	C.M.T. (TON.)	PRINCIPALES DIMENSIONES (MM)			PESO (KGS.)
			D	P	L	
PANI1000	ANI76	1.6	13	110	60	0.34
PANI2000	ANI87	1.6	13	110	60	0.34
PANI3000	ANI108	2.6	16	110	60	0.53
PANI4000	ANI1310	4.25	18	135	75	0.80





NOVEDADES

ANILLA MAESTRA EN
ACERO INOXIDABLE
G60

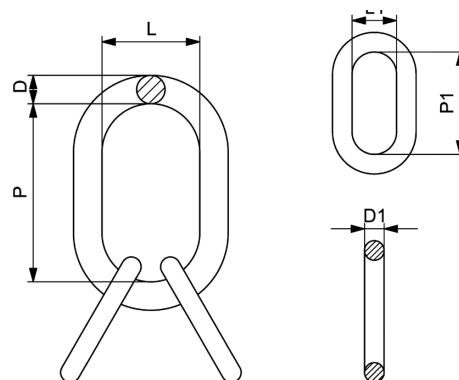

CODIGO	MODELO	C.M.T. (TON.)	PRINCIPALES DIMENSIONES (MM)						PESO (KGS.)
			D	P	L	D1	P1	L1	
PHAM1000	HAI-06	1.89	13	110	60	10	44	20	0.52
PHAM1500	HAI-07	2.6	16	110	60	13	54	25	0.97
PHAM2000	HAI-08	3.35	18	135	75	16	70	34	1.60
PHAM3000	HAI-10	5.25	22	160	90	18	85	40	2.76

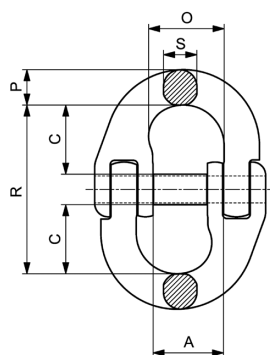

NOVEDADES

CONECTOR EN
ACERO INOXIDABLE
G60

CODIGO	MEDIDA	C.M.T. (TON.)	PRINCIPALES DIMENSIONES (MM)						PESO (KGS.)
			A	C	O	R	P	S	
PHH1000	6-6	900	14	18	18	45	8	7.5	0.08
PHH1500	7-6	1250	18	20	20.5	50.5	10.2	9	0.14
PHH2000	8-6	1600	19	25.5	23.5	62	11.5	10	0.20
PHH3000	10-6	2500	24	30	27.5	72	12.6	12.6	0.35



NOVEDADES

GANCHO CON
PESTILLO EN
ACERO INOXIDABLE
G60

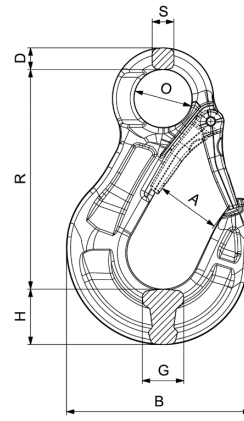

CODIGO	MEDIDA (MM.)	C.M.T. (TON.)	PRINCIPALES DIMENSIONES (MM)								PESO (KGS.)
			A	B	D	G	H	O	R	S	
PGI1000	6-6	0.90	23	72	8	13.5	21	21	90	8	0.31
PGI2000	8/7-6	1.60	32	103	13	19.5	29	27	118	13	0.81
PGI3000	10-6	2.50	39	120	15	27	33	37	140	15	1.57

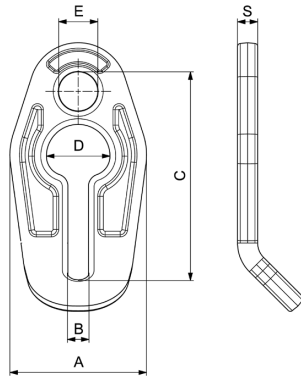

CODIGO	MEDIDA	C.M.T. (TON.)	PRINCIPALES DIMENSIONES (MM)						PESO (KGS.)
			A	B	C	D	E	S	
PGA1000	6-6	0.90	55	8	81	26	16	8.5	0.25
PGA12000	8/7-6	1.60	71	11	110	34	22	10.5	0.59
PGA13000	10-6	2.50	90	12	135	40	26	13	1.13

NOVEDADES

GANCHO
ACORTADOR EN
ACERO INOXIDABLE
G60



NOVEDADES

GRILLETE RECTO EN ACERO INOXIDABLE G60

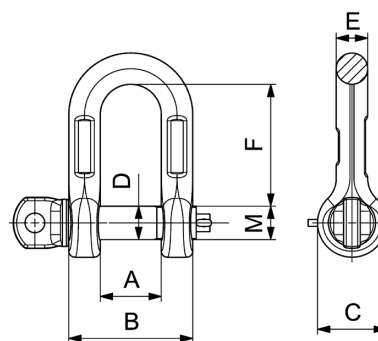

CODIGO	C.M.T. (TON.)	PRINCIPALES DIMENSIONES (MM)							PESO (KGS.)
		A	B	C	D	E	F	M	
AGRB10050	0.50	18	34	18	9	8	33	M10	0.07
AGRB10125	1.25	25	49	25	13	12	40	M14	0.22
AGRB10200	2.00	32	64	32	17	16	60	M18	0.52
AGRB10320	3.20	41	79	47	21	19	78	M22	0.80

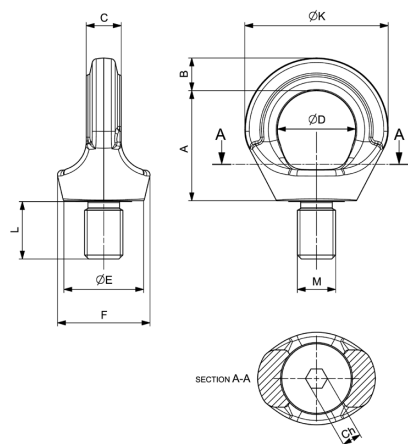

NOVEDADES

CÁNCAMO MACHO GIRATORIO EN ACERO INOXIDABLE G60

CODIGO	MEDIDA (MÉTRICA)	C.M.T. (TON.)	PRINCIPALES DIMENSIONES (MM)									PESO (KGS.)
			A	B	C	D	E	F	K	L	CH	
PHCMG112	12	0.50	43	12.5	11.5	30	30	36.5	55.5	18	8	0.20
PHCMG116	16	1.00	49.5	14.5	15.7	35	35	41.8	64.5	24	10	0.35
PHCMG120	20	2.00	58	16	18	40	42	51.5	74.5	30	12	0.60
PHCMG124	24	2.50	69	20.5	22	49	50	58	90	36	12	1.00



NOVEDADES

ESLINGAS DIVERSAS
DE CADENA EN
ACERO **INOXIDABLE**
G60



NOTA: FABRICACIÓN Y MONTAJES A MEDIDA SEGÚN NECESIDAD

ESLINGAS DE ACERO INOXIDABLE						
1 RAMAL	2 RAMALES		3 RAMALES	4 RAMALES	ESLINGA SIN FIN EN AHORCADO	
CADENA Ø (MM.)	C.M.T.	0° < β ≤ 45° FACTOR 1,4	45° < β ≤ 60° FACTOR 1,0	0° < β ≤ 45° FACTOR 2,1	45° < β ≤ 60° FACTOR 1,5	FACTOR 1,6
6	0,90	1,25	0,90	1,89	1,35	1,44
7	1,25	1,75	1,25	2,60	1,85	2,00
8	1,60	2,2	1,60	3,35	2,40	2,50
10	2,50	3,50	2,50	5,25	3,75	4,00

NOVEDADES

ESLINGAS ESPECIALES
PARA BOMBAS EN
ACERO **INOXIDABLE**
G60







INDUSTRIAS JAGUAR, S.A.
APARATOS DE ELEVACIÓN
Y TRANSPORTE

Carretera N 1, Km. 443 | Apartado 23
20150 VILLABONA (Gipuzkoa) | ESPAÑA
Tel.: +34 943 691 283 | Fax: +34 943 691 850
jaguar@industriasjaguar.com

INDUSTRIASJAGUAR.COM