

GC MODEL

RACK JACKS



The JAGUAR rack jacks is designed on the principle of mechanical transmission.

The inconveniences of normal hydraulic jacks are overcome wherein in the event of oil loss this control disappears.

The high quality of its steel structure makes it safe, reliable and durable. Its compact design with folding lever makes possible the easy operation and simple maintenance.

Características:

- Folding lever.
- Two applicable support brackets.
- Higher elevation range.

• Note:

- It is one of the best tools used in repairs, maintenance, etc ...
- The lifting and lowering speed is controllable.

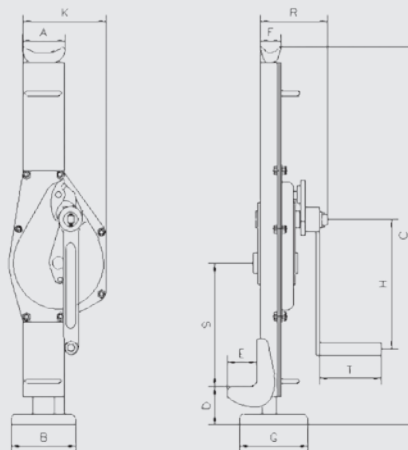

MODEL	CAPACITY (Kg)	FORCE (N.)	MAIN DIMENSIONS (mm)												NET WEIGHT (Kg)
			A	B	C	D	E	F	G	H	K	R	S	T	
GC-15	1.500	280	81	100	600-900	60-360	55	46	110	225	147	119	175	113	14
GC-30	3.000	350	83	130	730-1100	75-445	65	45	138	249	170	140	235	128	20
GC-50	5.000	400	108	140	730-1075	80-425	71	68	170	275	190	155	217	128	28
GC-100	10.000	580	124	140	800-1220	90-510	86	76	170	300	252	185	210	250	46,5
GC-160	16.000	640	135	150	795-1135	90-430	80	85	180	300	275	210	210	250	65

RECOMMENDED ACCESSORIES



ROLLERSKATES TROLLEYS
ATACA MODEL
Pag. 65



TROLLEY KITS
AKT MODEL
Pag. 66



LIFTING LEVER
APAEL MODEL
Pag. 67