

GPJM MODEL

MEDIUM CRANE SCALES

Very light weigher, compact, easy to transport and store.

Features:

- Extra large LED screen.
- Accurate.
- Rechargeable Battery.
- Comes with remote control and battery charger.
- Configuration possibility.
- Precision $\pm 0,05\%$.

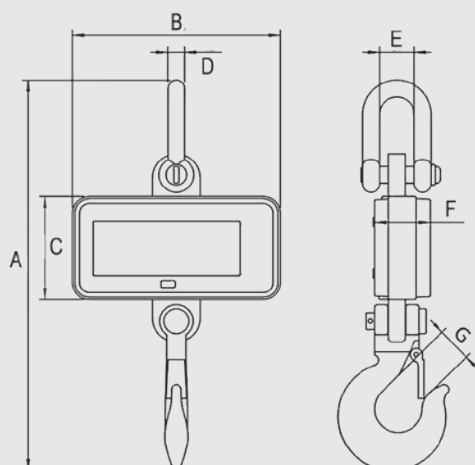

MODEL	CAPACITY (Kg.)	DIVISION (Kg.)	MAIN DIMENSIONS (mm)							NET WEIGHT (Kg.)
			A	B	C	D	E	F	G	
GPJM030	300	0,1	280	150	74	12	25	40	25	1,2
GPJM050	500	0,2	280	150	74	12	25	40	25	1,2
GPJM100	1000	0,5	280	150	74	12	25	40	25	1,2



**MANUAL CHAIN HOISTS
SERIES 630**
Pag. 20



**CHAIN HOIST
COMPACT MODEL**
Pag. 117



OVAL RING
Pag. 74