

TE MODEL

ELECTRIC WINCHES

The electric winches are tools for dragging and lifting, its new compact design facilitates installation.

Features:

- End of the electrical career.
- Light.
- High capacity cable.

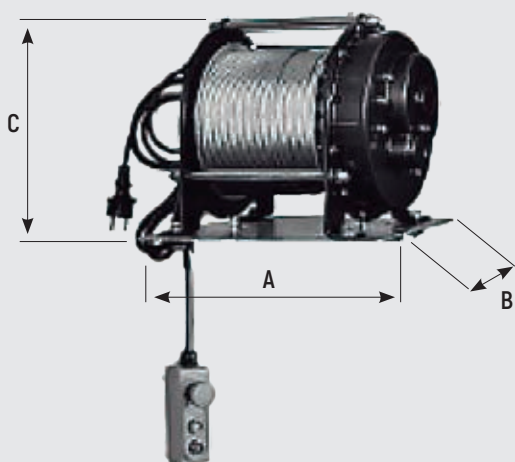

MAIN DIMENSIONS (mm)			NET WEIGHT (Kg)
A	B	C	
232	201	270	31

MODEL	TE 400
LOAD	400 kg.
SPEED	8 m./min.
TENSION	220V/50HZ
POWER	1.300 W
CABLE	5 m./m.
LENGHT	32 mts.

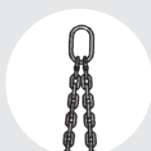

SLING "DO"
Pag. 80

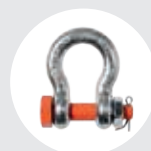

SHACKLES
Pag. 94